

MINIKIN

Product Catalogue

10th Edition

EMFLEX

Flexible Connectors, Expansion Joints and Related Equipment for Pipework Systems

With special reference to the
Building Services Industry

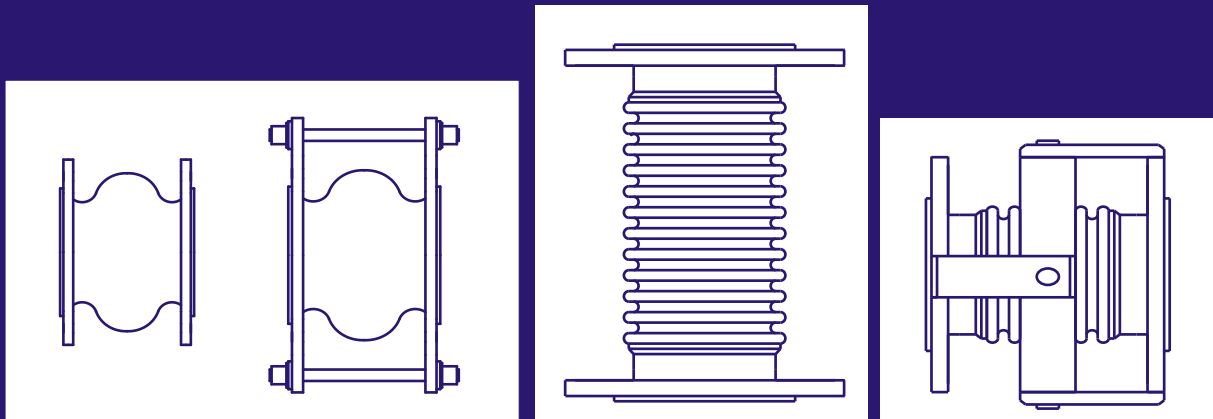

N. Minikin and Sons Limited
Spa House, Hookstone Park, Harrogate, North Yorkshire, HG2 7DB.
Tel: 01423 889845 Fax: 01423 880724
Email: minikin@dial.pipex.com
Web Site: www.minikin.dial.pipex.com



Certificate No. Q 5468

CONTENTS

3. CHLOROBUTYL RUBBER FLEXIBLE CONNECTORS
4. E.P.D.M. RUBBER FLEXIBLE CONNECTORS (125mm Long)
5. E.P.D.M. RUBBER FLEXIBLE CONNECTORS (150mm Long)
6. E.P.D.M. RUBBER FLEXIBLE CONNECTORS (TO DIN4809 STANDARD)
7. BUTYL / E.P.D.M. RUBBER FLEXIBLE CONNECTORS (TO D.V.G.W. STANDARD)
8. SCREWED BRAIDED FLEXIBLE CONNECTORS
9. FLANGED BRAIDED FLEXIBLE CONNECTORS
10. FANCOIL EQUIPMENT CONNECTORS
11. RUBBER HOSES & QUICK RELEASE COUPLINGS
12. CHILLED CEILING & BEAM CONNECTORS
13. CATERING EQUIPMENT CONNECTORS
14. SCREWED AXIAL EXPANSION JOINTS
15. FLANGED AXIAL EXPANSION JOINTS
16. FULLY ARTICULATED EXPANSION JOINTS
17. DOUBLE HINGED EXPANSION JOINTS
18. ANGULAR EXPANSION JOINTS
19. GIMBAL EXPANSION JOINTS
20. SINGLE ARTICULATED EXPANSION JOINTS (Single Tied Flexible Connector)
21. EXHAUST EXPANSION JOINTS
22. TAILOR-MADE INSULATION COVERS
23. FLEXIBLE DUCT CONNECTORS
24. APPENDIX 1. Flange Data
25. APPENDIX 2. Useful Conversion Factors
26. APPENDIX 3. Pipe Data Table
27. CONDITIONS OF BUSINESS

If you have any additional requirements for equipment relating to pipework movement then please ask, even if you do not see it listed here.

This catalogue has been compiled to provide a general selection of product information. For more specific details, technical information or in instances where you may wish to discuss a particular project please contact us.

We reserve the right to alter or amend any information detailed in this catalogue. E&OE.

© N. Minikin & Sons Ltd



Certificate No. Q 5468

This product catalogue presented by:

EMFLEX Chlorobutyl Rubber Flexible Connectors

EMFLEX chlorobutyl (often shortened to 'butyl') rubber flexible connectors are comprised of a synthetic rubber membrane reinforced with nylon. The collars are wire reinforced and the unit is complete with carbon steel flanges. They are capable of absorbing movement in several directions; axial compression, axial elongation and lateral deflection. A small amount of angular movement may also be allowed. They are normally installed in the pipework to isolate various items of plant which produce noise and vibration. These flexible connectors effectively dampen the transmission of sound and vibration from plant items in building services installations.

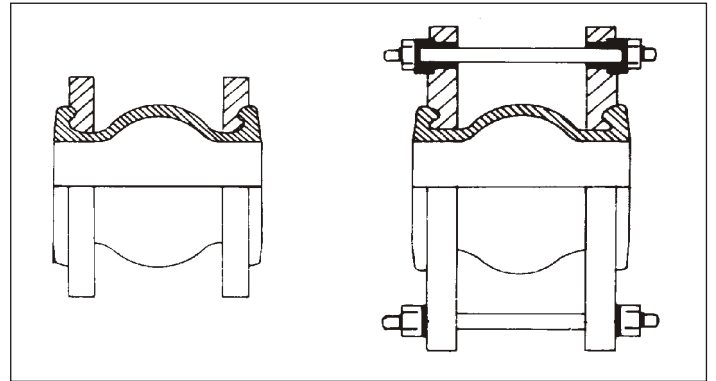

Type BB

Chlorobutyl rubber membrane reinforced with a nylon textile cord and fitted with 'untied' or 'tied' carbon steel flanges. Suitable for use with hot water and chilled water.



| Nominal Size | Installed Overall Length | Untied & Tied Units | Untied Units Only | Untied & Tied Units |
|--------------|--------------------------|---------------------|-------------------|---------------------|
| | | Axial Compression | Axial Elongation | Lateral Deflection |
| mm | mm | mm | mm | mm |
| 25 | 95 | 8 | 4 | 8 |
| 32 | 95 | 8 | 4 | 8 |
| 40 | 95 | 8 | 4 | 8 |
| 50 | 105 | 8 | 4 | 8 |
| 65 | 115 | 12 | 6 | 10 |
| 80 | 130 | 12 | 6 | 10 |
| 100 | 135 | 18 | 10 | 12 |
| 125 | 170 | 18 | 10 | 12 |
| 150 | 180 | 18 | 10 | 12 |
| 200 | 205 | 25 | 14 | 22 |
| 250 | 240 | 25 | 14 | 22 |

Vacuum support rings are available.

Working Pressure:

4 bar (400 kPa) for 'untied' units, unless the pipe is secured.
10 bar (1000 kPa) for 'tied' units with top hat washers.
16 bar (1600 kPa) for 'tied' units with hemispherical washers.

Test Pressure: 1.5 x Working Pressure.

Working Temperature: -10°C to 100°C.

Key Features:

Fully traceable and has the date of manufacture, nominal diameter, manufacturer, and type permanently moulded into the membrane.

Noise and vibration reduction capabilities. Tied units are fitted with noise absorbing top hat washers.

Design Consideration:

Rubber flexible connectors are subject to the same internal pressure force as metal expansion joints and the force is equal to the internal pressure multiplied by the maximum internal area. This force causes the connector to lengthen and tied units are recommended where the working pressure exceeds 4 bar, unless the pipework is secured to restrict movement.

Tie-rods are fitted through oval flanges and to isolate the tie-rods from the flanges special neoprene top hat washers are used to prevent any metal to metal contact whatsoever, effectively preventing noise transmission.

After installation of TIED UNITS the tie-rod nuts should be checked to have 1mm clearance over the steel washers.

When using with items of plant mounted on vibration isolators, such as springs or inertia bases, then TIED UNITS must be installed.

EMFLEX

EPDM Rubber Flexible Connectors (125mm long)

EMFLEX EPDM (Ethylene Propylene Diene Monomer) rubber flexible connectors are comprised of a synthetic rubber membrane reinforced with nylon. The collars are wire reinforced and the unit is complete with carbon steel flanges. They are capable of absorbing movement in several directions; axial compression, axial elongation and lateral deflection. A small amount of angular movement may also be allowed. They are normally installed in the pipework to isolate various items of plant which produce noise and vibration. These flexible connectors effectively dampen the transmission of sound and vibration from plant items in building services installations.

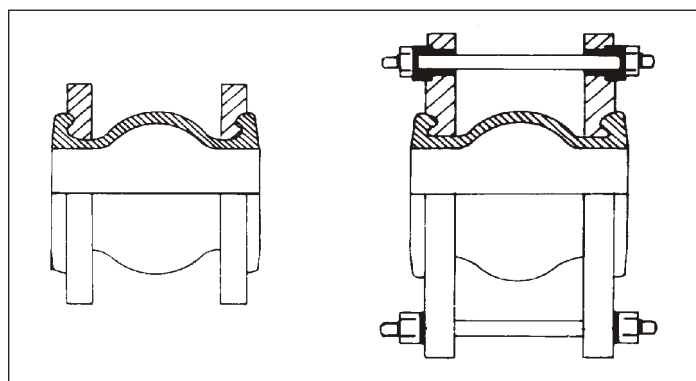

Type EE

EPDM rubber membrane reinforced with a nylon textile cord and fitted with 'untied' or 'tied' carbon steel flanges. Suitable for use with hot water and chilled water.



| Nominal Size | Installed Overall Length | Untied & Tied Units | Untied Units Only | Untied & Tied Units |
|--------------|--------------------------|---------------------|-------------------|---------------------|
| | | Axial Compression | Axial Elongation | Lateral Deflection |
| mm | mm | mm | mm | mm |
| 25 | 125 | 12 | 9 | 12 |
| 32 | 125 | 12 | 9 | 12 |
| 40 | 125 | 12 | 9 | 12 |
| 50 | 125 | 12 | 9 | 12 |
| 65 | 125 | 12 | 9 | 12 |
| 80 | 125 | 12 | 9 | 12 |
| 100 | 125 | 14 | 9 | 12 |
| 125 | 125 | 14 | 9 | 12 |
| 150 | 125 | 14 | 9 | 12 |
| 200 | 125 | 14 | 9 | 12 |
| 250 | 125 | 14 | 9 | 12 |

Vacuum support rings are available.

Working Pressure:

4 bar (400 kPa) for 'untied' units, unless the pipe is secured.
10 bar (1000 kPa) for 'tied' units with top hat washers.
16 bar (1600 kPa) for 'tied' units with hemispherical washers.

Test Pressure: 1.5 x Working Pressure.

Working Temperature: -10°C to 100°C.

Key Features:

Fully traceable and has the date of manufacture, nominal diameter, manufacturer, and type permanently moulded into the membrane.

Noise and vibration reduction capabilities. Tied units are fitted with noise absorbing top hat washers.

Design Consideration:

Rubber flexible connectors are subject to the same internal pressure force as metal expansion joints and the force is equal to the internal pressure multiplied by the maximum internal area. This force causes the connector to lengthen and tied units are recommended where the working pressure exceeds 4 bar, unless the pipework is secured to restrict movement.

Tie-rods are fitted through oval flanges and to isolate the tie-rods from the flanges special neoprene top hat washers are used to prevent any metal to metal contact whatsoever, effectively preventing noise transmission.

After installation of TIED UNITS the tie-rod nuts should be checked to have 1mm clearance over the steel washers.

When using with items of plant mounted on vibration isolators, such as springs or inertia bases, then TIED UNITS must be installed.

EMFLEX

EPDM Rubber Flexible Connectors (150mm long)

EMFLEX EPDM (Ethylene Propylene Diene Monomer) rubber flexible connectors are comprised of a synthetic rubber membrane reinforced with nylon. The collars are wire reinforced and the unit is complete with carbon steel flanges. They are capable of absorbing movement in several directions; axial compression, axial elongation and lateral deflection. A small amount of angular movement may also be allowed. They are normally installed in the pipework to isolate various items of plant which produce noise and vibration. These flexible connectors effectively dampen the transmission of sound and vibration from plant items in building services installations.

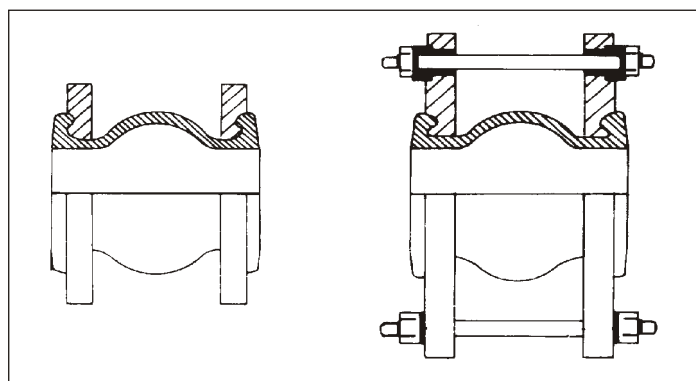

Type EE

EPDM rubber membrane reinforced with a nylon textile cord and fitted with 'untied' or 'tied' carbon steel flanges. Suitable for use with hot water and chilled water.



| Nominal Size | Installed Overall Length | Untied & Tied Units | Untied Units Only | Untied & Tied Units |
|--------------|--------------------------|---------------------|-------------------|---------------------|
| | | Axial Compression | Axial Elongation | Lateral Deflection |
| mm | mm | mm | mm | mm |
| 25 | 150 | 12 | 9 | 12 |
| 32 | 150 | 12 | 9 | 12 |
| 40 | 150 | 12 | 9 | 12 |
| 50 | 150 | 12 | 9 | 12 |
| 65 | 150 | 12 | 9 | 12 |
| 80 | 150 | 12 | 9 | 12 |
| 100 | 150 | 14 | 9 | 12 |
| 125 | 150 | 14 | 9 | 12 |
| 150 | 150 | 14 | 9 | 12 |
| 200 | 150 | 14 | 9 | 12 |

Vacuum support rings are available.

Working Pressure:

4 bar (400 kPa) for 'untied' units, unless the pipe is secured.
10 bar (1000 kPa) for 'tied' units with top hat washers.
16 bar (1600 kPa) for 'tied' units with hemispherical washers.

Test Pressure: 1.5 x Working Pressure.

Working Temperature: -10°C to 100°C.

Key Features:

Fully traceable and has the date of manufacture, nominal diameter, manufacturer, and type permanently moulded into the membrane.

Noise and vibration reduction capabilities. Tied units are fitted with noise absorbing top hat washers.

Design Consideration:

Rubber flexible connectors are subject to the same internal pressure force as metal expansion joints and the force is equal to the internal pressure multiplied by the maximum internal area. This force causes the connector to lengthen and tied units are recommended where the working pressure exceeds 4 bar, unless the pipework is secured to restrict movement.

Tie-rods are fitted through oval flanges and to isolate the tie-rods from the flanges special neoprene top hat washers are used to prevent any metal to metal contact whatsoever, effectively preventing noise transmission.

After installation of TIED UNITS the tie-rod nuts should be checked to have 1mm clearance over the steel washers.

When using with items of plant mounted on vibration isolators, such as springs or inertia bases, then TIED UNITS must be installed.

EMFLEX

EPDM Rubber Flexible Connectors to DIN4809

EMFLEX EPDM (Ethylene Propylene Diene Monomer) rubber flexible connectors are comprised of a synthetic rubber membrane reinforced with a high tensile polymer textile cord. The collars are wire reinforced and the unit is complete with carbon steel flanges. They are capable of absorbing movement in several directions; axial compression, axial elongation and lateral deflection. A small amount of angular movement may also be allowed. They are normally installed in the pipework to isolate various items of plant which produce noise and vibration. These flexible connectors effectively dampen the transmission of sound and vibration from plant items in building services installations.

Type RR

EPDM rubber membrane reinforced with a high tensile polymer textile cord and fitted with 'untied' or 'tied' carbon steel flanges. Suitable for use with hot water and chilled water. They are approved to DIN4809 for use in heating plants and are fully certified to this effect.

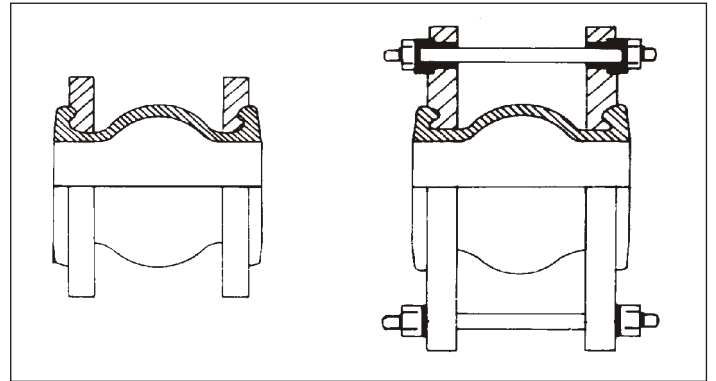

| Nominal Size | Installed Overall Length | Untied & Tied Units | Untied Units Only | Untied & Tied Units |
|--------------|--------------------------|---------------------|-------------------|---------------------|
| | | Axial Compression | Axial Elongation | Lateral Deflection |
| mm | mm | mm | mm | mm |
| 25 | 130 | 30 | 30 | 30 |
| 32 | 130 | 30 | 30 | 30 |
| 40 | 130 | 30 | 30 | 30 |
| 50 | 130 | 30 | 30 | 30 |
| 65 | 130 | 30 | 30 | 30 |
| 80 | 130 | 30 | 30 | 30 |
| 100 | 130 | 30 | 30 | 30 |
| 125 | 130 | 30 | 30 | 30 |
| 150 | 130 | 30 | 30 | 30 |
| 200 | 130 | 30 | 30 | 30 |
| 250 | 130 | 30 | 30 | 30 |
| 300 | 130 | 30 | 30 | 30 |

Vacuum support rings are available.

Working Pressure: 10 bar (1000 kPa)
Test Pressure: 1.5 x Working Pressure.
Working Temperature: -10°C to 100°C.

Key Features:

Complies with DIN4809 Parts 1 & 2 and is fully approved and certified to this effect.

Verified burst pressure of 30 bar gauge minimum after 10 years service. An increased safety point.

Fully traceable and has the date of manufacture, DIN approval registration number, pressure and temperature rating, nominal diameter, manufacturer, type and identifiable colour coding permanently moulded into the membrane.

Laboratory tested for noise and vibration reduction capabilities. Tied units are fitted with noise absorbing top hat washers.

Design Consideration:

Rubber flexible connectors are subject to the same internal pressure force as metal expansion joints and the force is equal to the internal pressure multiplied by the maximum internal area. This force causes the connector to lengthen and tied units are recommended where the working pressure exceeds 4 bar, unless the pipework is secured to restrict movement.

Tie-rods are fitted through profiled flanges and to isolate the tie-rods from the flanges rubber top hat washers are used to prevent any metal to metal contact whatsoever, effectively preventing noise transmission.

After installation of TIED UNITS the tie-rod nuts should be checked to have 1 mm clearance over the steel washers.

When using with plant items mounted on vibration isolators, such as springs or inertia bases, then TIED UNITS must be installed.

EMFLEX

Butyl/EPDM Rubber Flexible Connectors to DVGW

EMFLEX Butyl/EPDM compounded rubber flexible connectors are comprised of a synthetic rubber membrane reinforced with a nylon textile cord. The collars are wire reinforced and the unit is complete with carbon steel flanges. They are capable of absorbing movement in several directions; axial compression, axial elongation and lateral deflection. A small amount of angular movement may also be allowed. They are normally installed in the pipework to isolate various items of plant which produce noise and vibration. These flexible connectors effectively dampen the transmission of sound and vibration from plant items in building services and water supply installations.

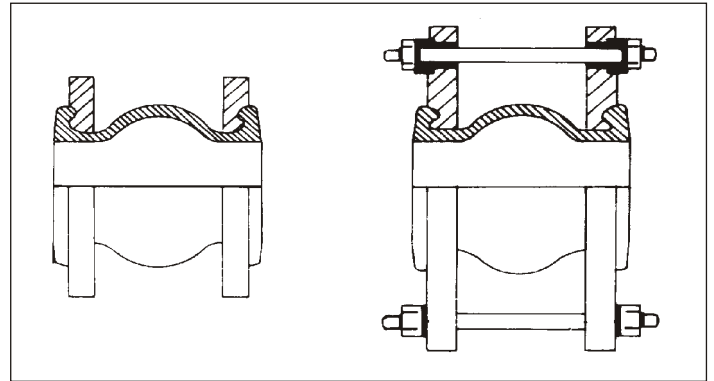

Type R

Butyl/EPDM rubber membrane reinforced with a nylon textile cord and fitted with 'untied' or 'tied' carbon steel flanges. Suitable for use with hot water, chilled water and drinking water. They are approved by DVGW for use with drinking water and are fully certified to this effect.



| Nominal Size | Installed Overall Length | Untied & Tied Units | Untied Units Only | Untied & Tied Units |
|--------------|--------------------------|---------------------|-------------------|---------------------|
| | | Axial Compression | Axial Elongation | Lateral Deflection |
| mm | mm | mm | mm | mm |
| 25 | 130 | 30 | 30 | 30 |
| 32 | 130 | 30 | 30 | 30 |
| 40 | 130 | 30 | 30 | 30 |
| 50 | 130 | 30 | 30 | 30 |
| 65 | 130 | 30 | 30 | 30 |
| 80 | 130 | 30 | 30 | 30 |
| 100 | 130 | 30 | 30 | 30 |
| 125 | 130 | 30 | 30 | 30 |
| 150 | 130 | 30 | 30 | 30 |
| 200 | 130 | 30 | 30 | 30 |
| 250 | 130 | 30 | 30 | 30 |
| 300 | 130 | 30 | 30 | 30 |
| 350 | 200 | 30 | 30 | 30 |
| 400 | 200 | 30 | 30 | 30 |
| 500 | 200 | 30 | 30 | 30 |
| 600 | 200 | 30 | 30 | 30 |

Working Pressure: 10 bar (1000 kPa)
Test Pressure: 1.5 x Working Pressure.
Working Temperature: up to 90°C.

Key Features:

Complies with DVGW for use with drinking water and is fully approved and certified to this effect.

Fully traceable and has the date of manufacture, pressure and temperature rating, nominal diameter, manufacturer, type and identifiable colour coding permanently moulded into the membrane.

Noise and vibration reduction capabilities. Tied units are fitted with noise absorbing top hat washers up to 300mm nominal size. Tied units above 300mm nominal size are supplied with metal hemispherical washers.

Design Consideration:

Rubber flexible connectors are subject to the same internal pressure force as metal expansion joints and the force is equal to the internal pressure multiplied by the maximum internal area. This force causes the connector to lengthen and tied units are recommended where the working pressure exceeds 4 bar, unless the pipework is secured to restrict movement.

Tie-rods are fitted through profiled flanges and to isolate the tie-rods from the flanges rubber top hat washers are used to prevent any metal to metal contact whatsoever, effectively preventing noise transmission (nominal sizes up to 300mm only).

After installation of TIED UNITS the tie-rod nuts should be checked to have 1mm clearance over the steel washers.

When using with plant items mounted on vibration isolators, such as springs or inertia bases, then TIED UNITS must be installed.

EMFLEX

Screwed Braided Flexible Connectors

EMFLEX braided flexible connectors are used to suppress vibration from pumps, to absorb intermittent lateral movement in pipelines and to compensate for subsidence when pipelines cross building movement lines. They must be installed at right angles to the direction of movement when installed in pipelines and close to the suction and discharge connections when used on pumps. They are not suitable for absorbing AXIAL movement, but are an alternative to articulated or angular expansion joints for low velocity applications.

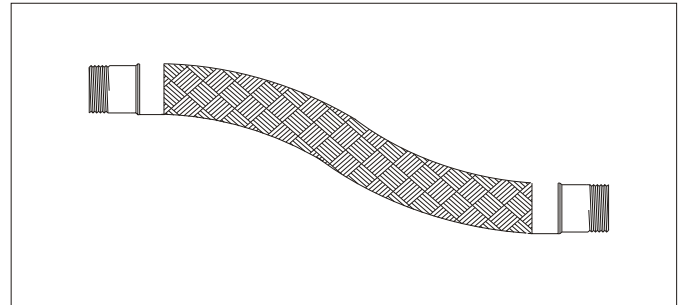

Type BBT

For use on steel pipelines and is suitable for steam and hot water for heating. This unit has stainless steel hose and overbraiding with fixed male BSP taper threads in carbon steel as standard.

Type BBTN

For use on copper pipelines and is suitable for condensate and domestic hot water. This unit has stainless steel hose and overbraiding with fixed male BSP taper threads in stainless steel as standard. This unit is also suitable for potable water, as all internal surfaces are stainless steel.

| Nominal Size | Minimum Bend Radius | Overall Length for +/-3mm Lateral Mvt. | Overall Length for +/- 12mm Lateral Mvt. | Overall Length for +/- 25mm Lateral Mvt. | Overall Length for +/- 50mm Lateral Mvt. |
|--------------|---------------------|--|--|--|--|
| mm | mm | mm | mm | mm | mm |
| 15 | 165 | 190 | 250 | 290 | 390 |
| 20 | 225 | 220 | 300 | 350 | 440 |
| 25 | 260 | 250 | 330 | 380 | 480 |
| 32 | 300 | 280 | 370 | 430 | 530 |
| 40 | 340 | 320 | 430 | 500 | 620 |
| 50 | 390 | 360 | 490 | 570 | 710 |

Other lengths and sizes are available.

Working Pressure: 16 bar (1600 kPa).
Test Pressure: 1.5 x Working Pressure.
Temperature: 185°C

Material Specifications:

Convuluted hose and overbraid are stainless steel.
 For steel service the threaded ends are carbon steel.
 For copper service the threaded ends are stainless steel.

End fittings available:

A wide range of different end fittings are available; please contact us for more information. Please note, however, that the stated overall lengths for a given lateral movement will change with different end fittings.

Design Consideration:

The overall lengths in the table are for flexing applications. When using these units on static applications, for example subsidence, they will absorb 1.5 times the lateral movements shown.

For installation details see our design book.

Notice

Braided flexible connectors must not be used to absorb AXIAL compression or elongation.
 Do not exceed the minimum bend radius.
 Do not stretch or twist the unit.

Rotary Unions, Swivel Joints and Quick Release Couplings are available.

Type BBTA and BBTNA

As type BBT and BBTN above but with 'Armaflex' insulation applied over the braiding.

Temperature: 105°C

Type BBTP and BBTNTP

As type BBT and BBTN above but with a smooth plastic shrink fit cover applied over the braiding. Available in red, blue, green, yellow, black and white.

Temperature: 90°C

EMFLEX

Flanged Braided Flexible Connectors

EMFLEX braided flexible connectors are used to suppress vibration from pumps, to absorb intermittent lateral movement in pipelines and to compensate for subsidence when pipelines cross building movement lines. They must be installed at right angles to the direction of movement when installed in pipelines and close to the suction and discharge connections when used on pumps. They are not suitable for absorbing AXIAL movement, but are an alternative to articulated or angular expansion joints for low velocity applications.

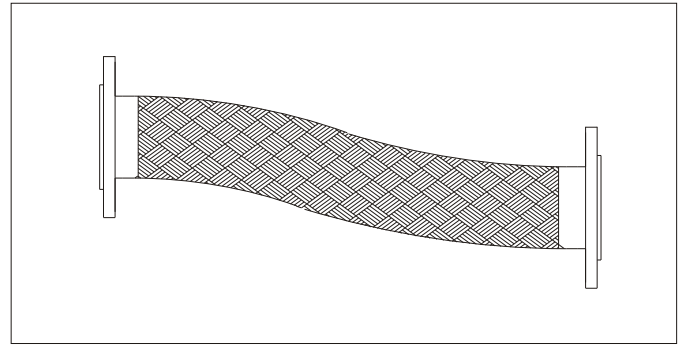

Type BBF

For use on steel pipelines and is suitable for steam and hot water for heating. This unit has stainless steel hose and overbraiding with flanges of carbon steel.

Type BBFN

For use on copper pipelines and is suitable for condensate and domestic hot water. This unit has stainless steel hose and overbraiding with ends having stainless steel to all internal surfaces. Hence, this unit is also suitable for potable water.

| Nominal Size | Minimum Bend Radius | Overall Length for +/-3mm Lateral Mvt. | Overall Length for +/- 12mm Lateral Mvt. | Overall Length for +/- 25mm Lateral Mvt. | Overall Length for +/- 50mm Lateral Mvt. |
|--------------|---------------------|--|--|--|--|
| mm | mm | mm | mm | mm | mm |
| 15 | 165 | 140 | 200 | 240 | 340 |
| 20 | 225 | 160 | 230 | 280 | 370 |
| 25 | 260 | 170 | 250 | 310 | 400 |
| 32 | 300 | 180 | 280 | 330 | 440 |
| 40 | 340 | 220 | 330 | 400 | 520 |
| 50 | 390 | 260 | 390 | 470 | 610 |
| 65 | 500 | 290 | 430 | 520 | 680 |
| 80 | 525 | 310 | 470 | 590 | 770 |
| 100 | 625 | 330 | 510 | 630 | 820 |
| 125 | 750 | 360 | 550 | 670 | 880 |
| 150 | 900 | 400 | 630 | 770 | 1030 |
| 200 | 1020 | 440 | 680 | 830 | 1110 |
| 250 | 1220 | 500 | 750 | 900 | 1220 |

Other lengths and sizes are available.

Working Pressure:

Using carbon steel PN16 flanges and single overbraid.

| Nominal Size | 20°C | 100°C | 150°C |
|--------------|-------|--------|--------|
| 15-80mm | 16bar | 16bar | 14bar |
| 100mm | 14bar | 13bar | 12bar |
| 125mm | 10bar | 9.5bar | 8.5bar |
| 150mm | 8bar | 7.5bar | 7bar |
| 200mm | 7bar | 6.5bar | 6bar |
| 250mm | 6bar | 4.5bar | 4bar |

N.B. A higher working pressure can be achieved using double overbraid.

Test Pressure: 1.5 x Working Pressure.

Material Specifications:

Convolute hose and overbraid are stainless steel.
For steel service the flanges are carbon steel.
For copper service all wetted surfaces are stainless steel.

Design Consideration:

The overall lengths in the table are for flexing applications. When using these units on static applications, for example subsidence, they will absorb 1.5 times the lateral movements shown.

For installation details see our design book.

Notice

Braided flexible connectors must not be used to absorb AXIAL compression or elongation.
Do not exceed the minimum bend radius.
Do not stretch or twist the unit.

EMFLEX Fancoil Equipment Connectors

EMFLEX fancoil equipment connectors are used as the final connection to fancoil units. They are designed to offer a high degree of flexibility to allow for misalignment of the pipework and the suppression of possible vibration from the fancoil unit. The basic hose connector is available in varying standard lengths, although almost any length can be manufactured. Double shut-off quick release couplings are available to allow immediate removal of the fancoil unit in the event of break-down or for maintenance purposes. A great deal of time and money can be saved by an engineer if the need to drain down is eliminated by the use of hoses and quick release couplings.

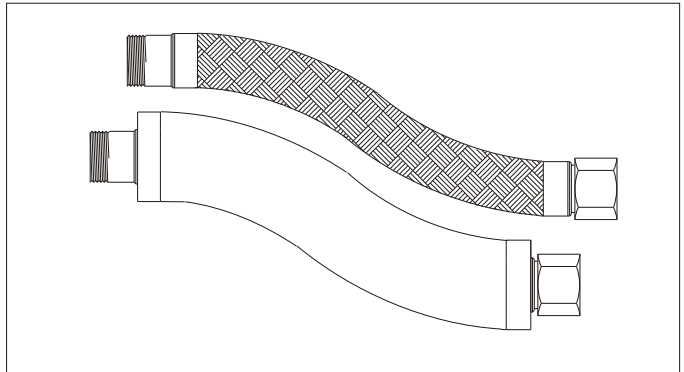

Type FCH

A stainless steel hose and overbraiding with carbon steel end fittings. Suitable for heating circuits.

Type FCHA

A stainless steel hose and overbraiding with carbon steel end fittings. Complete with 'Armaflex' insulation: Class 'O' - minimum thickness 9mm. With vapour seal. Particularly suitable for chilled water circuits.

| Nominal Size | Minimum Static Bend Radius | Overall Length 1 | Overall Length 2 | Overall Length 3 |
|--------------|----------------------------|------------------|------------------|------------------|
| mm | mm | mm | mm | mm |
| 15 | 65 | 300 | 450 | 600 |
| 20 | 75 | 300 | 450 | 600 |
| 25 | 90 | 300 | 450 | 600 |

Larger sizes and alternative lengths are available on special request.

Working Pressure: 16 bar (1600 kPa).

Test Pressure: 1.5 x Working Pressure.

Temperature: 95°C maximum.

End fittings available:

1. Fixed male BSP taper thread.
2. Fixed male BSP parallel thread.
3. Flat faced female swivel nut, BSP parallel thread.
4. Cone seat full male BSP union.
5. Cone seat full female BSP union.
6. All above with 90 degree elbow.
7. Compression fitting.
8. Copper tail, 50mm long.

Type FCHN and FCHNA

As type FCH and FCHA above but with stainless steel end fittings.

Please note that the stated overall lengths may need to increase with the use of different end fittings.

Type FCQ

A double shut off quick release coupling for use with fancoil units. This unit is manufactured from brass and stainless steel components with nitrile rubber seals. It has a nickel plated finish as standard and has a single body size for both 15mm and 20mm nominal sizes. An automatic shut off valve is designed into both the female half (also known as the 'coupler' or 'socket') and the male half (also known as the 'plug'). It can be disconnected and reconnected easily with minimal spillage.

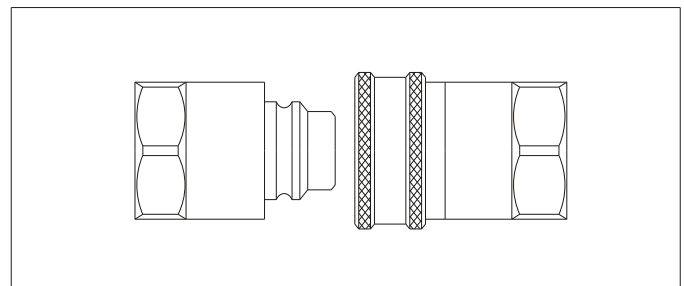

Type FCQ-T

As type FCQ above but with varying body sizes available from 15mm to 50mm nominal sizes, with self colour brass finish as standard.

End fittings available:

Fixed female BSP parallel threads; for FCQ the joint is made on a washer at the bottom of the thread; for FCQ-T the joint is made on the thread.

Working Pressure: 16 bar (1600 kPa).

Test Pressure: 1.5 x Working Pressure.

Temperature: 95°C maximum.

(For safety upon disconnection by uncovered hand.)

Notice

When installing the hoses do not exceed the minimum static bend radius.
Do not stretch or twist the hose.
Use only BSP Parallel male threads with the quick release coupling.
Do not allow ammonia contamination of the brass coupling body.
Do not allow soldering flux damage.

EMFLEX Rubber Hoses & Quick Release Couplings

EMFLEX rubber hoses are used as an economical final connection to fancoil units. They are designed to offer a high degree of flexibility to allow for misalignment of the pipework and the suppression of possible vibration from the fancoil unit. The basic hose connector is available in varying standard lengths, although almost any length can be manufactured. Double shut-off quick release couplings are available to allow immediate removal of the fancoil unit in the event of break-down or for maintenance purposes. A great deal of time and money can be saved by an engineer if the need to drain down is eliminated by the use of hoses and quick release couplings.

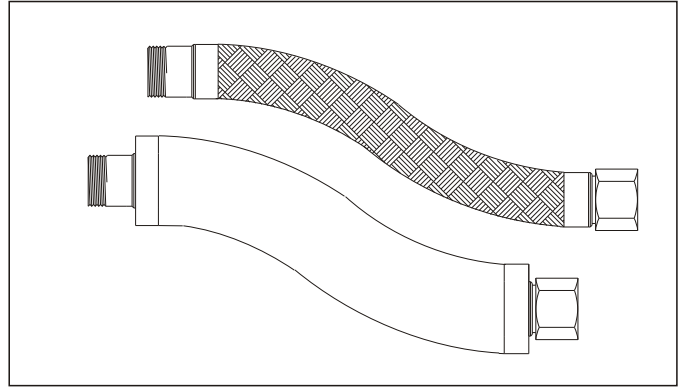

Type RH

A high quality EPDM hose and stainless steel over braiding with nickel plated brass end fittings. Suitable for heating circuits. BSRIA cycle tested in excess of an estimated 12 yrs of simulated operation.

Type RHA

A high quality EPDM hose and stainless steel over braiding with nickel plated brass end fittings. With 9mm thick 'Armaflex' Class '0' insulation and vapour seal. Suitable for chilled water circuits.

| Nominal Size | Minimum Static Bend Radius | Overall Length 1 | Overall Length 2 | Overall Length 3 |
|--------------|----------------------------|------------------|------------------|------------------|
| mm | mm | mm | mm | mm |
| 15 | 70 | 300 | 450 | 600 |
| 20 | 90 | 300 | 450 | 600 |
| 25 | 110 | 300 | 450 | 600 |

Larger sizes and alternative lengths are available on special request.

Working Pressure: 10 bar (1000 kPa) for all sizes.

Test Pressure: 1.5 x Working Pressure.

Temperature: 90°C maximum.

Note that higher working pressures are allowable: 15mm NB up to 20bar with temperature limitation. 20mm NB up to 16bar with temperature limitation.

End fittings available:

1. Fixed male BSP taper thread.
2. Flat faced female swivel nut, BSP parallel thread, for use with rubber washer.
3. Compression fitting.
4. Brass standpipe.
5. All above with 90 degree elbow.

Please note that the stated overall lengths may need to increase with the use of different end fittings.



Type FCQ

A double shut off quick release coupling for use with fancoil units. This unit is manufactured from brass and stainless steel components with nitrile rubber seals. It has a nickel plated finish as standard and has a single body size for both 15mm and 20mm nominal sizes. An automatic shut off valve is designed into both the female half (also known as the 'coupler' or 'socket') and the male half (also known as the 'plug'). It can be disconnected and reconnected easily with minimal spillage.

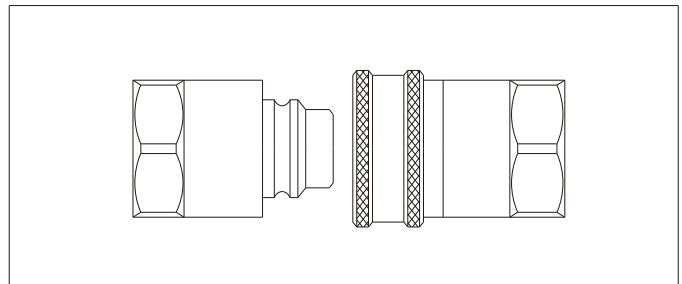

Type FCQ-T

As type FCQ above but with varying body sizes available from 15mm to 50mm nominal sizes, with self colour brass finish as standard.

Working Pressure: 16 bar (1600 kPa).

Test Pressure: 1.5 x Working Pressure.

Temperature: 95°C maximum.

(For safety upon disconnection by uncovered hand.)

End fittings available:

Fixed female BSP parallel threads; for FCQ the joint is made on a fibre washer at the bottom of the thread; for FCQ-T the joint is made on the thread.

Notice

When installing the hoses do not exceed the minimum static bend radius.
Do not stretch or twist the hose.
Use only BSP Parallel male threads with the quick release coupling.
Do not allow ammonia contamination of the brass coupling body.

EMFLEX

Chilled Ceiling & Beam Connectors

EMFLEX chilled ceiling and chilled beam connectors are used as a flexible connection to and between units. They are designed to offer a high degree of flexibility to allow for misalignment of the pipework and ease of connection between adjacent units. The basic hose connector is available in varying standard lengths, although almost any length can be manufactured, depending of course upon the amount of flexibility required. Used in conjunction with propriety push-fit sockets, they provide the engineer with a fast and economical flexible link.

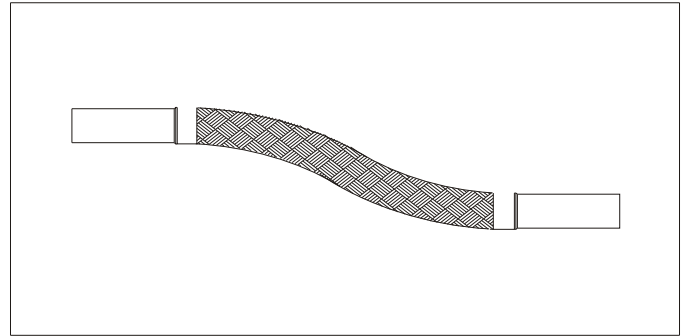

Type CHH

A stainless steel hose and overbraiding with silver-soldered copper tail end fittings. Suitable for chilled water circuits.

| Nominal Size (Copper Tube O/D) | Minimum Static Bend Radius | Overall Length 1 | Overall Length 2 | Overall Length 3 |
|-----------------------------------|-------------------------------|---------------------|---------------------|---------------------|
| mm | mm | mm | mm | mm |
| 10 | 65 | 500 | 1000 | 1500 |
| 12 | 65 | 500 | 1000 | 1500 |
| 15 | 65 | 500 | 1000 | 1500 |

Alternative lengths are available on special request.

Working Pressure: 10 bar (1000 kPa) as standard.
15 bar (1500 kPa) on request.

Test Pressure: 15 bar (1500 kPa) as standard.
30 bar (3000 kPa) on request.

Material Specifications:

Convoluted hose and overbraid are stainless steel.
End fittings are copper.

End fittings available:

Copper tail pieces are supplied as standard for use with push-fit fittings or for direct soldering.

Push-fit fittings can be supplied for working pressures up to 15 bar @ 30 deg.C., with a cold test pressure of 30 bar.

Other end fittings can be supplied; please contact us for more information.

Notice

When installing the hoses do not exceed the minimum static bend radius.
Do not stretch or twist the hose.
Do not solder the unit in place unless wet cloths are used to prevent damaging the attachment of the copper tube to the stainless steel hose.
Do not allow soldering flux damage.

EMFLEX

Catering Equipment Connectors

EMFLEX catering equipment connectors are used to enable catering appliances to be moved easily for regular cleaning, in line with legislation for hygiene in kitchens. They are installed between the mains supply and the catering appliance and are finished with a plastic cover which can be easily wiped clean.

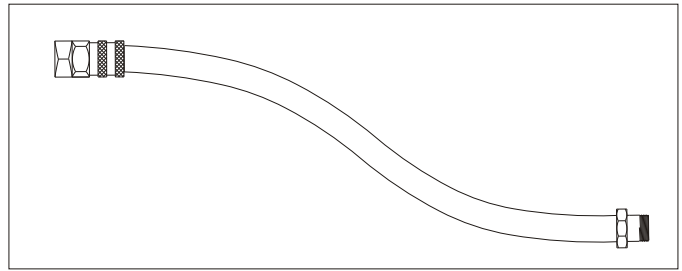

Type CATG

A flexible hose and quick release coupling for use on gas service. This unit has stainless steel hose with carbon steel ends, an integral quick release coupling (15mm, 20mm and 25mm NB only), a smooth yellow plastic shrink fit cover to denote gas, and restraining wire as standard.

This unit is both leak-proof and fire-proof and is in accordance with BS669 Part 2, 1997 and is British Gas approved.

End fittings available:

1. Fixed male BSP taper thread.
2. Single shut off quick release coupling.

Working Pressure: 3 bar (300 kPa).

Test Pressure: 1.5 x Working Pressure.

Temperature: 90°C maximum.

Type CATW

A flexible hose for use on water service. This unit has stainless steel hose and overbraiding with stainless steel end fittings and a smooth white plastic shrink fit cover as standard. A quick release coupling is optional; see type CATQ below. This unit is leak-proof and has all internal surfaces manufactured from material grades accepted by the WRc.

This unit can be supplied with a full red, blue or green plastic cover to distinguish between different water services; alternatively coloured bands can be shrink fitted to denote the service.

End fittings available:

1. Fixed male BSP taper thread.
2. Fixed female BSP taper thread.
3. Cone seat full male BSP union.
4. Cone seat full female BSP union.
5. Flat face female swivel BSP nut.
6. All above with 90 degree elbow.

Working Pressure: 16 bar (1600 kPa).

Test Pressure: 1.5 x Working Pressure.

Temperature: 90°C maximum.

| Nominal Size | Minimum Bend Radius | Nominal Length 1 | Nominal Length 2 | Nominal Length 3 | Nominal Length 4 |
|--------------|---------------------|------------------|------------------|------------------|------------------|
| mm | mm | mm | mm | mm | mm |
| 15 | 150 | 500 | 1000 | 1250 | 1500 |
| 20 | 200 | 500 | 1000 | 1250 | 1500 |
| 25 | 225 | 500 | 1000 | 1250 | 1500 |

Larger sizes and alternative lengths are available on special request.
(Note larger size CATG not with integral quick release coupling)

Type CATQ

A quick release coupling for use on water service. This unit is manufactured entirely from stainless steel with WRc approved rubber seals. It is used in conjunction with type CATW above and can be supplied with a double shut off valve configuration or a straight through non shut off configuration.

End fittings available:

1. Fixed female BSP thread.

Working Pressure: 16 bar (1600 kPa).

Test Pressure: 1.5 x Working Pressure.

Temperature: 90°C maximum.

Notice

When installing the hoses do not exceed the minimum bend radius.
Do not stretch or twist the hose.
Do not install where contact can be made with equipment whose temperature exceeds 90°C.
Do not allow chloride, chlorine or chlorite contamination of the convoluted stainless steel hose wall.

EMFLEX

Screwed Axial Expansion Joints

EMFLEX axial expansion joints with screwed ends are used to absorb thermal expansion in straight pipelines. They are installed in the pipeline and anchors are required to withstand the forces set up in the pipeline due mainly to the internal pressure in the bellows. Correct alignment of the pipeline is essential with this type of expansion joint and proper pipe alignment guides are recommended. Only one axial expansion joint should be installed between each pair of anchors.

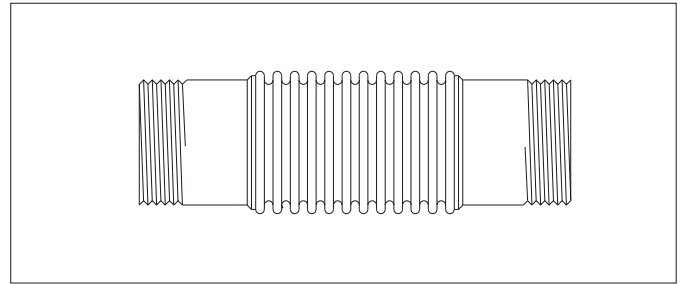

Type BAT

For use on steel pipelines and is suitable for steam and hot water for heating. This unit has stainless steel bellows, inner sleeve and carbon steel ends with male BSP taper thread.

Type BATN

For use on copper pipelines and is suitable for condensate and domestic hot water. This unit has stainless steel bellows, inner sleeve and stainless steel ends with male BSP taper thread.

| Nominal Size | Axial Compression | Installed Overall Length | Force To Compress | Effective Area |
|--------------|-------------------|--------------------------|-------------------|-----------------|
| mm | mm | mm | Newtons / mm | cm ² |
| 15 | 25 | 200 | 15 | 4 |
| 20 | 25 | 200 | 15 | 6 |
| 25 | 25 | 200 | 13 | 10 |
| 32 | 25 | 210 | 31 | 16 |
| 40 | 25 | 220 | 31 | 21 |
| 50 | 25 | 250 | 34 | 35 |

| | | | | |
|----|----|-----|----|----|
| 15 | 50 | 340 | 8 | 4 |
| 20 | 50 | 330 | 8 | 6 |
| 25 | 50 | 330 | 6 | 10 |
| 32 | 50 | 340 | 15 | 16 |
| 40 | 50 | 340 | 16 | 21 |
| 50 | 50 | 370 | 17 | 35 |

Other sizes and movements are available.

External protective sleeves are available, suffix E, e.g. BATE and BATNE.

Working Pressure: 16 bar (1600 kPa).

Test Pressure: 1.5 x Working Pressure.

Temperature: 185°C maximum.

Design Consideration:

For details of pipe anchors and alignment guides see our design book.

Axial expansion joints can be supplied at a compressed length for use as contraction joints on chilled water services.

Material Specifications:

Bellows and internal sleeves are stainless steel.

For steel service the tube ends are carbon steel with male BSP taper thread.

For copper service the tube ends are stainless steel with male BSP taper thread.

Notice

All axial expansion joints are pre-stressed at the factory and are supplied at the installation length.

EMFLEX

Flanged Axial Expansion Joints

EMFLEX axial expansion joints are used to absorb thermal expansion in straight pipelines. They are installed in the pipeline and substantial anchors are required to withstand the forces set up in the pipeline due mainly to the internal pressure in the bellows. Correct alignment of the pipeline is essential with this type of expansion joint and proper pipe alignment guides are recommended. Only one axial expansion joint should be installed between each pair of anchors.

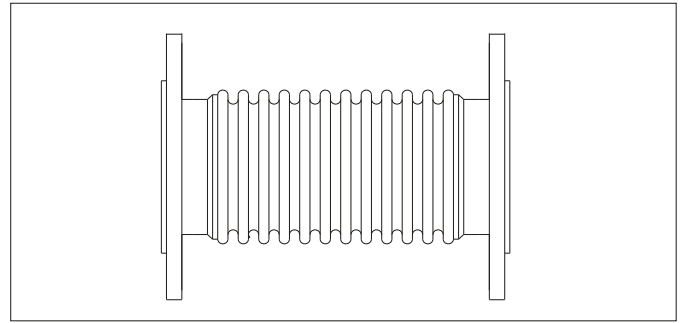

Type BAF

For use on steel pipelines and is suitable for steam and hot water for heating. This unit has stainless steel bellows and inner sleeve with flanges of carbon steel.

Type BAFN

For use on copper pipelines and is suitable for condensate and domestic hot water. This unit has stainless steel internals comprising stainless steel bellows, inner sleeve and van-stone ends with backing flanges of carbon steel.

| Nominal Size | Axial Compression | Installed Overall Length | Force To Compress | Effective Area |
|--------------|-------------------|--------------------------|-------------------|-----------------|
| mm | mm | mm | Newtons/mm | cm ² |
| 50 | 50 | 233 | 70 | 35 |
| 65 | 50 | 233 | 90 | 56 |
| 80 | 50 | 233 | 200 | 75 |
| 100 | 50 | 233 | 250 | 118 |
| 125 | 60 | 288 | 300 | 187 |
| 150 | 60 | 288 | 350 | 260 |
| 200 | 70 | 321 | 350 | 440 |
| 250 | 70 | 321 | 450 | 665 |

Other sizes and movements are available.

External protective sleeves are available, suffix E, e.g. BAFE and BAFNE.

Working Pressure: 16 bar (1600 kPa).

Test Pressure: 1.5 x Working Pressure.

Press./Temp. ratings for carbon steel PN16 Flanges.

| | | | | | |
|----------------------|-----|-----|-----|-----|-----|
| Design Temp. (°C) | 120 | 150 | 200 | 250 | 300 |
| Working Press. (Bar) | 16 | 14 | 12 | 11 | 9 |

Design Consideration:

For details of pipe anchors and alignment guides see our design book.

Axial expansion joints can be supplied at a compressed length for use as contraction joints on chilled water services.

Material Specifications:

Bellows and internal sleeve are stainless steel.

For steel service the flanges are carbon steel.

For copper service van-stone ends are stainless steel and backing flanges are carbon steel.

Notice

All axial expansion joints are pre-stressed at the factory and are supplied at the installation length.

EMFLEX

Fully Articulated Expansion Joints

EMFLEX fully articulated expansion joints consist of two bellows connected by a piece of pipe which permits a pipeline to move in any lateral direction, with each bellows moving through an angle of up to +/-5 degrees. These units are pressure restrained, being fitted with tie-rods, so they impose only small forces within the system and light anchors are sufficient. The main applications are where large movements have to be accommodated in the piping system or where it is impossible to fit heavy anchors.

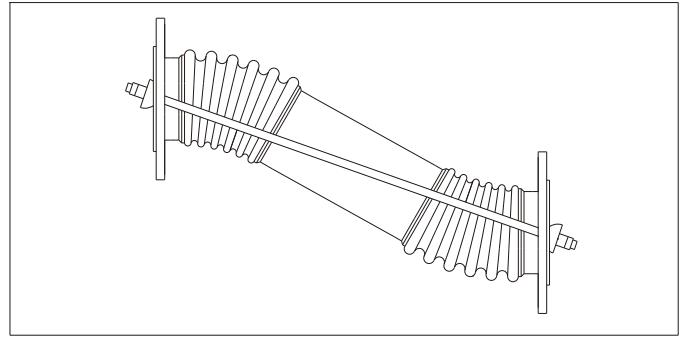

Type BLF

For use on steel pipelines and is suitable for steam and hot water for heating. This unit has two stainless steel bellows and inner sleeves with carbon steel intermediate pipe, flanges and tie-rods.

Type BLFN

For use on copper pipelines and is suitable for condensate and domestic hot water. This unit has stainless steel internals comprising stainless steel bellows, inner sleeves, intermediate pipe and van-stone ends with carbon steel backing flanges and tie-rods.

| Nominal Size | Installed Length for +/- 25mm mvt. | Force required for Maximum Deflection | Additional Length per +/- 25mm mvt. Increase |
|--------------|------------------------------------|---------------------------------------|--|
| mm | mm | Newtons | mm |
| 50 | 510 | 80 | 285 |
| 65 | 540 | 100 | 285 |
| 80 | 590 | 150 | 285 |
| 100 | 670 | 170 | 285 |
| 125 | 670 | 290 | 285 |
| 150 | 720 | 700 | 285 |
| 200 | 740 | 1400 | 285 |
| 250 | 780 | 2500 | 285 |

Other sizes are available.
External protective sleeves are available.

Working Pressure: 16 bar (1600 kPa).

Test Pressure: 1.5 x Working Pressure.

Press./Temp. ratings for carbon steel PN16 Flanges.

| | | | | | |
|----------------------|-----|-----|-----|-----|-----|
| Design Temp. (°C) | 120 | 150 | 200 | 250 | 300 |
| Working Press. (Bar) | 16 | 14 | 12 | 11 | 9 |

Design Consideration:

For details of layouts, pipe anchors and alignment guides see our design book.

Material Specifications:

Bellows and internal sleeves are stainless steel.
For steel service the intermediate pipe, flanges and tie-rods are carbon steel.
For copper service the intermediate pipe and van-stone ends are stainless steel, backing flanges and tie-rods are carbon steel.

EMFLEX

Double Hinged Expansion Joints

EMFLEX double hinged expansion joints consist of two bellows connected by a piece of pipe which permits a pipeline to move in a lateral direction in one plane only, with each bellows moving through an angle of up to +/-5 degrees. These units are pressure restrained, being fitted with hinges, so they impose only small forces within the system and light anchors are sufficient. The main applications are where large movements have to be accommodated in the piping system or where it is impossible to fit heavy anchors.

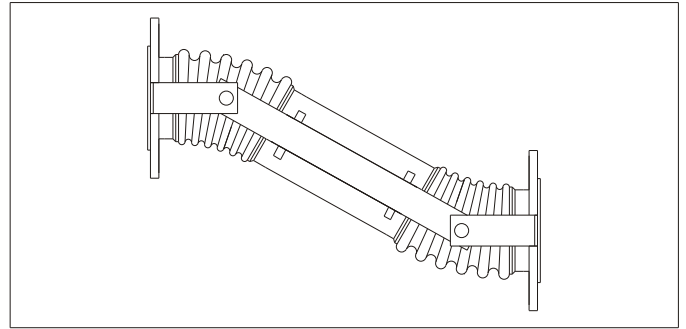

Type BDHF

For use on steel pipelines and is suitable for steam and hot water for heating. This unit has two stainless steel bellows and inner sleeves with carbon steel intermediate pipe, flanges and hinges.

Type BDHFN

For use on copper pipelines and is suitable for condensate and domestic hot water. This unit has stainless steel internals comprising stainless steel bellows, inner sleeves, intermediate pipe and van-stone ends with carbon steel backing flanges and hinges.

| Nominal Size | Installed Length for +/- 25mm mvt. | Force required for Maximum Deflection | Additional Length per +/- 25mm mvt. Increase |
|--------------|------------------------------------|---------------------------------------|--|
| mm | mm | Newtons | mm |
| 50 | 510 | 80 | 285 |
| 65 | 540 | 100 | 285 |
| 80 | 590 | 150 | 285 |
| 100 | 670 | 170 | 285 |
| 125 | 670 | 290 | 285 |
| 150 | 720 | 700 | 285 |
| 200 | 740 | 1400 | 285 |
| 250 | 780 | 2500 | 285 |

Other sizes are available.
External protective sleeves are available.

Working Pressure: 16 bar (1600 kPa).
Test Pressure: 1.5 x Working Pressure.

Design Consideration:
 For details of layouts, pipe anchors and alignment guides see our design book.

Press./Temp. ratings for carbon steel PN16 Flanges.

| | | | | | |
|----------------------|-----|-----|-----|-----|-----|
| Design Temp. (°C) | 120 | 150 | 200 | 250 | 300 |
| Working Press. (Bar) | 16 | 14 | 12 | 11 | 9 |

Material Specifications:

Bellows and internal sleeves are stainless steel.
 For steel service the intermediate pipe, flanges and hinges are carbon steel.
 For copper service the intermediate pipe and van-stone ends are stainless steel, backing flanges and hinges are carbon steel.

EMFLEX Angular Expansion Joints

EMFLEX angular expansion joints are effectively a hinged bend in the pipeline and allow the pipe to bend through an angle in one plane only of up to +/-5 degrees. These units are pressure restrained, being fitted with hinges, so they impose only small forces within the system and light anchors are sufficient. The main applications are where large movements have to be accommodated in the piping system or where it is impossible to fit heavy anchors.

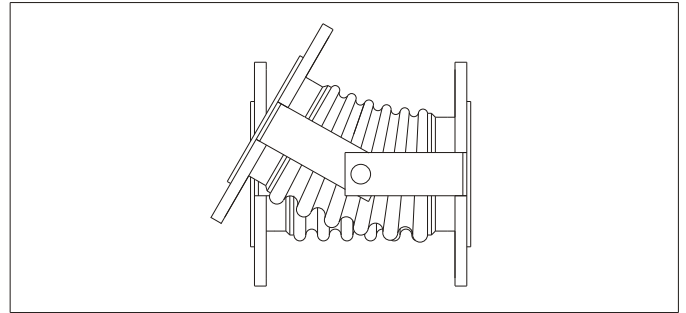

Type BHF

For use on steel pipelines and is suitable for steam and hot water for heating. This unit has stainless steel bellows and inner sleeve with carbon steel flanges and hinges.

Type BHFN

For use on copper pipelines and is suitable for condensate and domestic hot water. This unit has stainless steel internals comprising stainless steel bellows, inner sleeve and van-stone ends with carbon steel backing flanges and hinges.

| Nominal Size | Installed Length | Angular Rate | Force required for Maximum Deflection |
|--------------|------------------|--------------|---------------------------------------|
| mm | mm | Nm / degree | Newtons |
| 50 | 133 | 4.1 | 21 |
| 65 | 133 | 4.8 | 24 |
| 80 | 133 | 13.6 | 68 |
| 100 | 133 | 26.6 | 133 |
| 125 | 202 | 30.7 | 154 |
| 150 | 202 | 50.3 | 252 |
| 200 | 218 | 105.0 | 525 |
| 250 | 218 | 192.0 | 960 |

Other sizes are available.
External protective sleeves are available.

Working Pressure: 16 bar (1600 kPa).

Test Pressure: 1.5 x Working Pressure.

Press./Temp. ratings for carbon steel PN16 Flanges.

| | | | | | |
|----------------------|-----|-----|-----|-----|-----|
| Design Temp. (°C) | 120 | 150 | 200 | 250 | 300 |
| Working Press. (Bar) | 16 | 14 | 12 | 11 | 9 |

Design Consideration:

Force for maximum deflection is based on two joints with a distance of one metre between the hinge pins of the joints. Maximum angular movement of each joint is +/- 5 degrees. For details of layouts, pipe anchors and alignment guides see our design book.

Material Specifications:

Bellows and internal sleeve are stainless steel.
For steel service the flanges and hinges are carbon steel.
For copper service van-stone ends are stainless steel, backing flanges and hinges are carbon steel.

EMFLEX

Gimbal Expansion Joints

EMFLEX gimbal expansion joints are effectively a universally hinged bend in the pipeline allowing the pipe to bend in any direction through an angle of up to +/-5 degrees. These units are pressure restrained, being fitted with hinges, so they impose only small forces within the system and light anchors are sufficient. The main applications are where large movements have to be accommodated in the piping system or where it is impossible to fit heavy anchors.

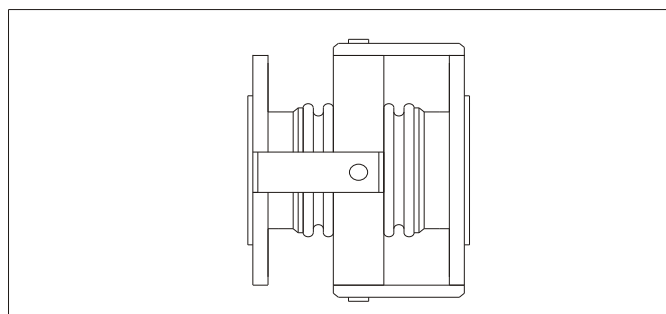

Type BGF

For use on steel pipelines and is suitable for steam and hot water for heating. This unit has stainless steel bellows and inner sleeve with carbon steel flanges, gimbal ring and hinges.

Type BGFN

For use on copper pipelines and is suitable for condensate and domestic hot water. This unit has stainless steel internals comprising stainless steel bellows, inner sleeve and van-stone ends with carbon steel backing flanges, gimbal ring and hinges.

| Nominal Size | Installed Length | Angular Rate | Force required for Maximum Deflection |
|--------------|------------------|--------------|---------------------------------------|
| mm | mm | Nm / degree | Newtons |
| 50 | 180 | 4.1 | 21 |
| 65 | 180 | 4.8 | 24 |
| 80 | 180 | 13.6 | 68 |
| 100 | 180 | 26.6 | 133 |
| 125 | 225 | 30.7 | 154 |
| 150 | 225 | 50.3 | 252 |
| 200 | 250 | 105.0 | 525 |
| 250 | 250 | 192.0 | 960 |

Other sizes are available.
External protective sleeves are available.

Working Pressure: 16 bar (1600 kPa).

Test Pressure: 1.5 x Working Pressure.

Press./Temp. ratings for carbon steel PN16 Flanges.

| | | | | | |
|----------------------|-----|-----|-----|-----|-----|
| Design Temp. (°C) | 120 | 150 | 200 | 250 | 300 |
| Working Press. (Bar) | 16 | 14 | 12 | 11 | 9 |

Design Consideration:

Force for maximum deflection is based on two joints with a distance of one metre between the hinge pins of the joints. Maximum angular movement of each joint is +/- 5 degrees. For details of layouts, pipe anchors and alignment guides see our design book.

Material Specifications:

Bellows and internal sleeve are stainless steel.
For steel service the flanges, gimbal ring and hinges are carbon steel.

For copper service van-stone ends are stainless steel, backing flanges, gimbal ring and hinges are carbon steel.

EMFLEX

Single Articulated Expansion Joints (Single Untied or Tied Flexible Connector)

EMFLEX single articulated expansion joints (also known as single 'untied' or 'tied' flexible connectors) are used to absorb vibration in pumped systems and misalignment in pipework systems. They are usually installed at the pump suction and discharge connections. The tie rods prevent elongation due to the internal pressure thrust. The units are not intended to absorb vibration and misalignment simultaneously. Axial thrust must not be applied to these units, for example when pipework is mounted vertically from the unit. In this situation the pipework should be supported using spring supports.

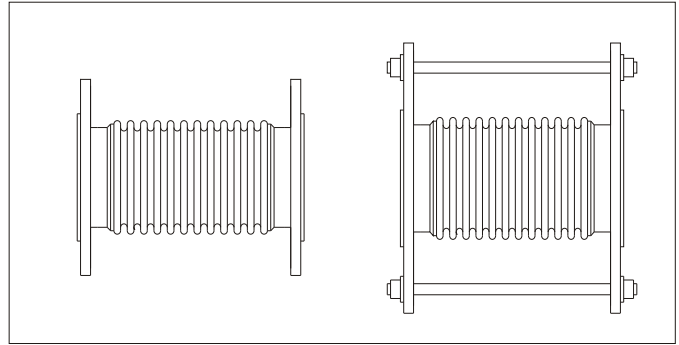

Type BFC

For use on steel pipelines and is suitable for steam and hot water for heating. This unit has stainless steel bellows and inner sleeve with carbon steel 'untied' or 'tied' flanges.

Type BFCN

For use on copper pipelines and is suitable for condensate and domestic hot water. This unit has stainless steel internals comprising stainless steel bellows, inner sleeve and van-stone ends with carbon steel 'untied' or 'tied' backing flanges.

| Nominal Size | Installed Length | Vibration Movement | Lateral Deflection at 10 bar |
|--------------|------------------|--------------------|------------------------------|
| mm | mm | +/- mm | mm |
| 50 | 130 | 0.75 | 2 |
| 65 | 130 | 0.75 | 2 |
| 80 | 130 | 0.75 | 2 |
| 100 | 130 | 0.75 | 2 |
| 125 | 130 | 0.75 | 2 |
| 150 | 130 | 0.75 | 2 |
| 200 | 200 | 0.75 | 2 |
| 250 | 200 | 0.75 | 2 |

Other sizes are available.
External protective sleeves are available.

Working Pressure: 16 bar (1600 kPa).

Test Pressure: 1.5 x Working Pressure.

Press./Temp. ratings for carbon steel PN16 Flanges.

| | | | | | |
|----------------------|-----|-----|-----|-----|-----|
| Design Temp. (°C) | 120 | 150 | 200 | 250 | 300 |
| Working Press. (Bar) | 16 | 14 | 12 | 11 | 9 |

Design Consideration:

Single tied flexible connectors are used on high temperature pumps etc where conventional rubber flexible connectors do not have sufficient temperature capability (i.e. above 100°C)

They are usefully employed to relieve stresses on boiler crown valves and other vulnerable plant connection points.

Material Specifications:

Bellows and internal sleeve are stainless steel.
For steel service the flanges and tie rods are carbon steel.
For copper service van-stone ends are stainless steel; backing flanges and tie rods are carbon steel.

EMFLEX Exhaust Expansion Joints

EMFLEX exhaust expansion joints are used to absorb thermal expansion in exhaust pipework and to compensate for vibration and exhaust pulsation from engines and generators, for example on CHP (Combined Heat & Power) plant. They are often installed on engine outlets and in the pipework. They are suitable for exhaust gas pulsing pressures at high temperatures. It must be noted that turbochargers are sensitive pieces of equipment, therefore care must be taken when connecting expansion joints to the outlets. The following types of unit can be used for different requirements.

Type BAFX

Single axial exhaust expansion joints are used to absorb thermal expansion in straight pipelines or to absorb small vibrations in the system.

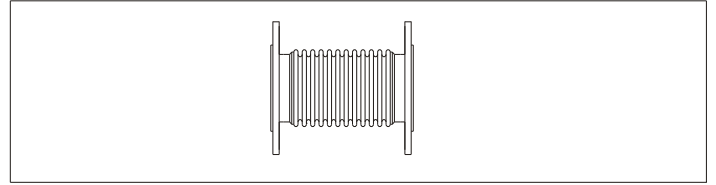

Type BDFX

Double exhaust expansion joints are used to absorb a combination of axial and lateral thermal expansion in pipelines. They are often used on the exhaust outlet where they compensate for vibration and thermal changes within the system.

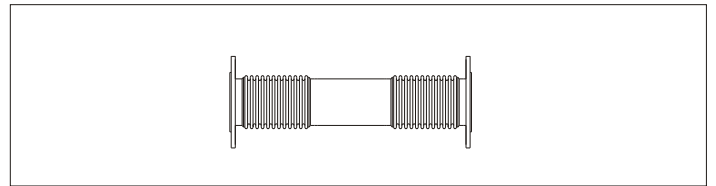

Type BLFX

Fully articulated exhaust expansion joints are used to absorb thermal expansion in any lateral direction.

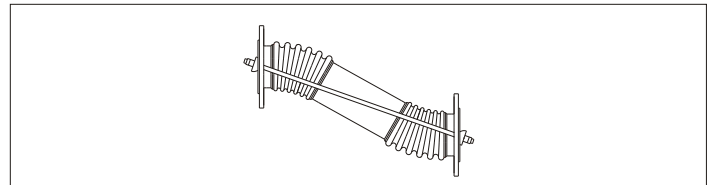

Type BDHFX

Double hinged exhaust expansion joints are used to absorb thermal expansion in a lateral direction in one plane only.

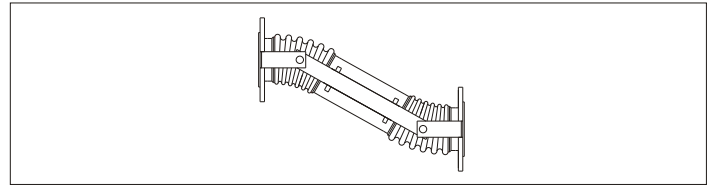

Type BHFX

Angular exhaust expansion joints are used usually in twos or threes to absorb thermal expansion by allowing the pipe to bend at specific calculated positions.

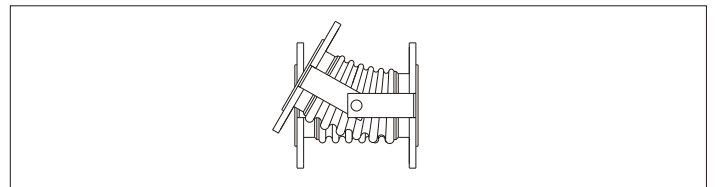

Type BGFX

Gimbal exhaust expansion joints are used in twos or threes to absorb thermal expansion by allowing the pipe to bend universally at specific calculated positions.

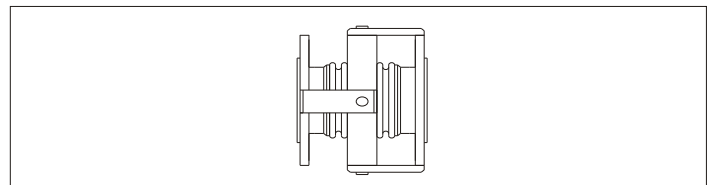

Type BFCX

Single articulated exhaust expansion joints are used to absorb small amounts of lateral movement and vibration where a tied unit is called for.

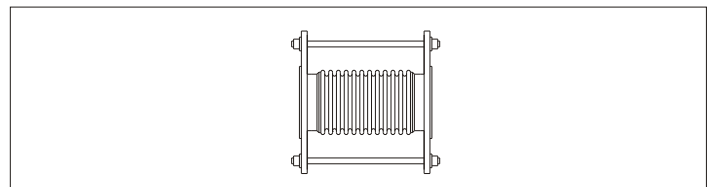

Type BBFX

Braided exhaust expansion joints are used to absorb lateral movement and vibration, or to allow for a misalignment between exhaust outlet and pipework. They are installed at right-angles to any thermal expansion.

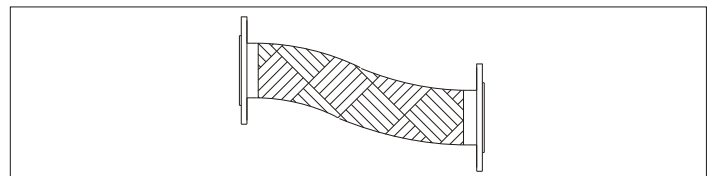

For further details about exhaust applications see our design book or contact our technical department.

EMFLEX Tailor-made Insulation Covers

EMFLEX tailor-made insulation covers are used with pipeline equipment such as expansion joints and flexible connectors, that are often difficult to cover with conventional insulation methods.

They are designed to be flexible so that the expansion joint or flexible connector can move as intended. They are quickly fitted and are easily removed and cleaned. Once fitted, they maintain a low surface temperature.



Type TMC

Insulation covers are tailored to suit the particular item of pipeline equipment. Covers are pre-designed for all our standard expansion joints and flexible connectors.

Fitting:

The insulation cover wraps around the expansion joint or flexible connector and is secured along its length by velcro securing straps. In addition, draw strings at each end of the cover are used to tighten and secure the cover to either the pipework or the insulation surrounding the pipework.

Material Specifications:

Cover material is a silicone coated glass cloth. The silicone coat ensures that the cover is waterproof. The glass cloth is class 'O' fire rated and will withstand 260 deg. C. Higher temperatures can be accommodated if required.

Insulation material is a ceramic fibre infill.

EMFLEX Flexible Duct Connectors

EMFLEX flexible duct connectors are used to suppress vibration and noise from plant items such as fans, VAV units and air handling units, to absorb movement in ductwork or to allow for subsidence movement. They are capable of absorbing movement in both axial and lateral directions without imposing stresses on the ductwork.

They can be manufactured from a wide range of materials to suit particular applications. Almost any shape or configuration can be manufactured such as circular, rectangular, as well as transition pieces, reducers and offsets. Almost any size can be manufactured, although standard ductwork sizes are preferred. Various methods of fixing can be incorporated into the units.

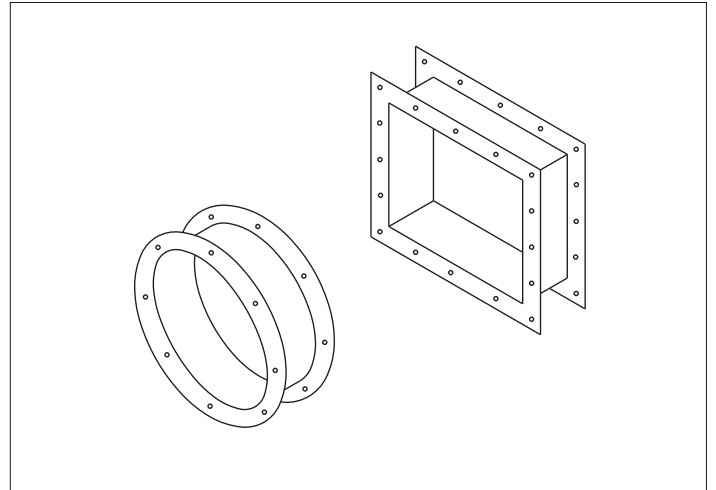

Type FDC

For use on all types of ductwork in the building engineering services industry.

Methods of Fixing:

The best method for fixing is by using flanged ductwork and clamping the flexible membrane between the flange and steel backing flats which are fastened with bolts, nuts and washers. This method is suitable for circular or rectangular ductwork and gives a high degree of air-tightness. See Figure 1.

Note: The flexible membrane and backing flats will normally be supplied undrilled.

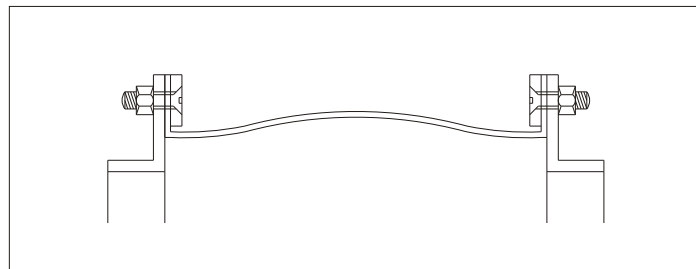

Fig 1

Another method for fixing is when connecting to circular ductwork with plain spigot ends. Here clamping bands or worm-drive bands are used to clamp the flexible membrane. See Figure 2.

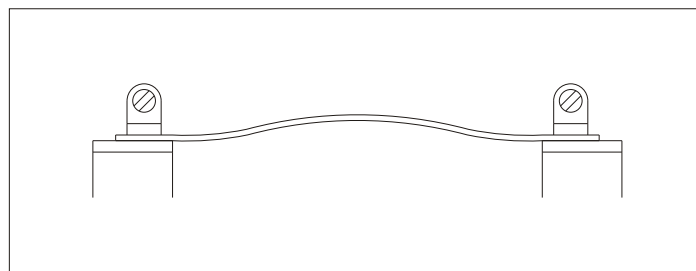

Fig 2

Material Specifications:

For most H & V applications within buildings, a neoprene coated glass cloth is used for the flexible membrane. This is resistant to flame and conforms to BS476, Parts 7 & 8, having a fire rating of 2 hours. Backing flats and clamping bands are normally steel, although stainless steel can be supplied upon request.

Note:

Other membrane materials are available. Acoustic barrier materials can be incorporated.

Appendix 1 Flange Data Table

| Nominal Size | Flange Table | Outer Dia. | No. of Bolt Holes | Bolt Hole Dia. | Bolt Circle (P.C.D) |
|--------------|--------------|------------|-------------------|----------------|---------------------|
| 15mm | E | 95 | 4 | 14 | 67 |
| | F | 95 | 4 | 14 | 67 |
| 1/2" | H | 114 | 4 | 18 | 83 |
| | 150 | 89 | 4 | 16 | 60 |
| | 300 | 95 | 4 | 16 | 67 |
| | 6 | 80 | 4 | 11 | 55 |
| | 10 | 95 | 4 | 14 | 65 |
| | 16 | 95 | 4 | 14 | 65 |
| | 25 | 95 | 4 | 14 | 65 |
| 20mm | E | 101 | 4 | 14 | 73 |
| | F | 101 | 4 | 14 | 73 |
| 3/4" | H | 114 | 4 | 18 | 83 |
| | 150 | 98 | 4 | 16 | 70 |
| | 300 | 117 | 4 | 19 | 83 |
| | 6 | 90 | 4 | 11 | 65 |
| | 10 | 105 | 4 | 14 | 75 |
| | 16 | 105 | 4 | 14 | 75 |
| | 25 | 105 | 4 | 14 | 75 |
| 25mm | E | 115 | 4 | 14 | 83 |
| | F | 121 | 4 | 18 | 87 |
| 1" | H | 121 | 4 | 18 | 87 |
| | 150 | 108 | 4 | 16 | 79 |
| | 300 | 124 | 4 | 19 | 89 |
| | 6 | 100 | 4 | 11 | 75 |
| | 10 | 115 | 4 | 14 | 85 |
| | 16 | 115 | 4 | 14 | 85 |
| | 25 | 115 | 4 | 14 | 85 |
| 32mm | E | 121 | 4 | 14 | 87 |
| | F | 133 | 4 | 18 | 98 |
| 1 1/4" | H | 133 | 4 | 18 | 98 |
| | 150 | 117 | 4 | 16 | 89 |
| | 300 | 133 | 4 | 19 | 98 |
| | 6 | 120 | 4 | 14 | 90 |
| | 10 | 140 | 4 | 18 | 100 |
| | 16 | 140 | 4 | 18 | 100 |
| | 25 | 140 | 4 | 18 | 100 |
| 40mm | E | 133 | 4 | 14 | 98 |
| | F | 140 | 4 | 18 | 105 |
| 1 1/2" | H | 140 | 4 | 18 | 105 |
| | 150 | 127 | 4 | 16 | 98 |
| | 300 | 155 | 4 | 22 | 114 |
| | 6 | 130 | 4 | 14 | 100 |
| | 10 | 150 | 4 | 18 | 110 |
| | 16 | 150 | 4 | 18 | 110 |
| | 25 | 150 | 4 | 18 | 110 |
| 50mm | E | 152 | 4 | 18 | 114 |
| | F | 165 | 4 | 18 | 127 |
| 2" | H | 165 | 4 | 18 | 127 |
| | 150 | 152 | 4 | 19 | 121 |
| | 300 | 165 | 8 | 19 | 127 |
| | 6 | 140 | 4 | 14 | 110 |
| | 10 | 165 | 4 | 18 | 125 |
| | 16 | 165 | 4 | 18 | 125 |
| | 25 | 165 | 4 | 18 | 125 |
| 65mm | E | 165 | 4 | 18 | 127 |
| | F | 184 | 8 | 18 | 146 |
| 2 1/2" | H | 184 | 8 | 18 | 146 |
| | 150 | 178 | 4 | 19 | 140 |
| | 300 | 191 | 8 | 22 | 149 |
| | 6 | 160 | 4 | 14 | 130 |
| | 10 | 185 | 4 | 18 | 145 |
| | 16 | 185 | 4 | 18 | 145 |
| | 25 | 185 | 8 | 18 | 145 |

| Nominal Size | Flange Table | Outer Dia. | No. of Bolt Holes | Bolt Hole Dia. | Bolt Circle (P.C.D) |
|--------------|--------------|------------|-------------------|----------------|---------------------|
| 80mm | E | 184 | 4 | 18 | 146 |
| | F | 203 | 8 | 18 | 165 |
| 3" | H | 203 | 8 | 18 | 165 |
| | 150 | 191 | 4 | 19 | 152 |
| | 300 | 210 | 8 | 22 | 168 |
| | 6 | 190 | 4 | 18 | 150 |
| | 10 | 200 | 8 | 18 | 160 |
| | 16 | 200 | 8 | 18 | 160 |
| | 25 | 200 | 8 | 18 | 160 |
| 100mm | E | 216 | 8 | 18 | 178 |
| | F | 229 | 8 | 18 | 191 |
| 4" | H | 229 | 8 | 18 | 191 |
| | 150 | 229 | 8 | 19 | 191 |
| | 300 | 254 | 8 | 22 | 200 |
| | 6 | 210 | 4 | 18 | 170 |
| | 10 | 220 | 8 | 18 | 180 |
| | 16 | 220 | 8 | 18 | 180 |
| | 25 | 235 | 8 | 22 | 190 |
| 125mm | E | 254 | 8 | 18 | 210 |
| | F | 279 | 8 | 22 | 235 |
| 5" | H | 279 | 8 | 22 | 235 |
| | 150 | 254 | 8 | 22 | 216 |
| | 300 | 279 | 8 | 22 | 235 |
| | 6 | 240 | 8 | 18 | 200 |
| | 10 | 250 | 8 | 18 | 210 |
| | 16 | 250 | 8 | 18 | 210 |
| | 25 | 270 | 8 | 26 | 220 |
| 150mm | E | 279 | 8 | 22 | 235 |
| | F | 305 | 12 | 22 | 260 |
| 6" | H | 305 | 12 | 22 | 260 |
| | 150 | 279 | 8 | 22 | 241 |
| | 300 | 318 | 12 | 22 | 270 |
| | 6 | 265 | 8 | 18 | 225 |
| | 10 | 285 | 8 | 22 | 240 |
| | 16 | 285 | 8 | 22 | 240 |
| | 25 | 300 | 8 | 26 | 250 |
| 200mm | E | 337 | 8 | 22 | 292 |
| | F | 368 | 12 | 22 | 324 |
| 8" | H | 368 | 12 | 22 | 324 |
| | 150 | 343 | 8 | 22 | 298 |
| | 300 | 381 | 12 | 25 | 330 |
| | 6 | 320 | 8 | 18 | 280 |
| | 10 | 340 | 8 | 22 | 295 |
| | 16 | 340 | 12 | 22 | 295 |
| | 25 | 360 | 12 | 26 | 310 |
| 250mm | E | 406 | 12 | 22 | 356 |
| | F | 432 | 12 | 25 | 381 |
| 10" | H | 432 | 12 | 25 | 381 |
| | 150 | 406 | 12 | 25 | 362 |
| | 300 | 444 | 16 | 29 | 387 |
| | 6 | 375 | 12 | 18 | 335 |
| | 10 | 395 | 12 | 22 | 350 |
| | 16 | 405 | 12 | 26 | 355 |
| | 25 | 425 | 12 | 30 | 370 |
| 300mm | E | 457 | 12 | 25 | 406 |
| | F | 489 | 16 | 25 | 438 |
| 12" | H | 489 | 16 | 25 | 438 |
| | 150 | 482 | 12 | 25 | 432 |
| | 300 | 521 | 16 | 32 | 451 |
| | 6 | 440 | 12 | 22 | 395 |
| | 10 | 445 | 12 | 22 | 400 |
| | 16 | 460 | 12 | 26 | 410 |
| | 25 | 485 | 16 | 30 | 430 |

E = BS10 Table 'E'
F = BS10 Table 'F'
H = BS10 Table 'H'

150 = BS1560 Class 150, ASA 150, ANSI B16.5 Class150.
300 = BS1560 Class 300, ASA 300, ANSI B16.5 Class300.

6 = BS4504 PN6, DIN2501 PN6.
10 = BS4504 PN10, DIN2501 PN10.
16 = BS4504 PN16, DIN2501 PN16.
25 = BS4504 PN25, DIN2501 PN25.

Appendix 2

Useful Conversion Factors

Pressure Units

| Symbol | Description | bar | kPa | kN/m ² | psi | atm | m wg |
|---------------------|-----------------------------|--------|----------|-------------------|---------|--------|---------|
| 1 bar | Bar | | 100.0 | 100.0 | 14.5037 | 0.9869 | 10.1972 |
| 1 kPa | Kilopascal | 0.01 | | 1.0 | 0.145 | 0.0099 | 0.102 |
| 1 kN/m ² | Kilonewton per square metre | 0.01 | 1.0 | | 0.145 | 0.0099 | 0.102 |
| 1 psi | Pound per square inch | 0.0689 | 6.8948 | 6.8948 | | 0.0681 | 0.7031 |
| 1 atm | Atmosphere | 1.0133 | 101.3250 | 101.3250 | 14.696 | | 10.3323 |
| 1 m wg | Metre water gauge | 0.0981 | 9.8067 | 9.8067 | 1.422 | 0.0968 | |

Vacuum Units

| Symbol | Description | mm Hg | in Hg | psi | Torr | bar | atm |
|---------|-----------------------|-------|--------|---------|------|--------|--------|
| 1 mm Hg | Millimetre of mercury | | 0.0394 | 0.49 | 1.0 | 0.0013 | 0.0013 |
| 1 in Hg | Inch of mercury | 25.4 | | 0.019 | 25.4 | 0.0338 | 0.0334 |
| 1 psi | Pound per square inch | 51.7 | 2.04 | | 51.7 | 0.0689 | 0.0681 |
| 1 Torr | Torr | 1.0 | 0.0394 | 0.49 | | 0.0013 | 0.0013 |
| 1 bar | Bar | 750 | 29.53 | 14.5037 | 750 | | 0.9869 |
| 1 atm | Atmosphere | 760 | 29.92 | 14.696 | 760 | 1.0133 | |

Linear Units

| Symbol | Description | mm | cm | m | in | ft | yd |
|--------|-------------|-------|-------|--------|---------|--------|--------|
| 1 mm | Millimetre | | 0.1 | 0.001 | 0.0394 | 0.0033 | 0.0011 |
| 1 cm | Centimetre | 10 | | 0.01 | 0.3937 | 0.0328 | 0.0109 |
| 1 m | Metre | 1000 | 100 | | 39.3701 | 3.2808 | 1.0936 |
| 1 in | Inch | 25.4 | 2.54 | 0.0254 | | 0.0833 | 0.0278 |
| 1 ft | Foot | 304.8 | 30.48 | 0.3048 | 12 | | 0.3333 |
| 1 yd | Yard | 914.4 | 91.44 | 0.9144 | 36 | 3 | |

Weight Units

| Symbol | Description | g | kg | t | oz | lb | tn |
|--------|----------------|---------|--------|-----------|----------|-----------|-----------|
| 1 g | Gramme | | 0.001 | 0.000001 | 0.036 | 0.0022 | 0.0000098 |
| 1 kg | Kilogramme | 1000 | | 0.001 | 36.413 | 2.2047 | 0.0009843 |
| 1 t | Tonne (metric) | 1000000 | 1000 | | 36413.44 | 2204.7222 | 0.984251 |
| 1 oz | Ounce | 28.4 | 0.0284 | 0.0000284 | | 0.0625 | 0.0000279 |
| 1 lb | Pound | 453.6 | 0.4536 | 0.0004536 | 16 | | 0.0004465 |
| 1 tn | Ton (imperial) | 1016000 | 1016 | 1.016 | 35840 | 2240 | |

Temperature Units

| Symbol | Description | °C | °F | °K |
|--------|-------------------|----------------------|-------------------------|-------------------------|
| °C | Degree Celsius | | Times 1.8, plus 32 | Plus 273.16 |
| °F | Degree Fahrenheit | Minus 32, divide 1.8 | | Divide 1.8, plus 255.38 |
| °K | Degree Kelvin | Minus 273.16 | Minus 255.38, times 1.8 | |

Appendix 3 Pipe Data Table

| Nominal Size | Material | Wall Thickness | Max O/D | Min O/D | Mean I/D | Int Cross-section Area | Metal Cross-section Area | Surface Area / Metre Length | Moment Of Inertia | Section Modulus | Pipe Weight | Water Content | Support Centres |
|------------------------------|------------------|----------------|---------|---------|----------|------------------------|--------------------------|-----------------------------|-------------------|-----------------|-------------|---------------|-----------------|
| | | mm | mm | mm | mm | mm ² | mm ² | m ² | cm ⁴ | cm ³ | kg/m | l/m | m |
| 15mm 1/2" | Heavy steel | 3.25 | 21.7 | 21.1 | 14.9 | 175 | 186 | 0.067 | 0.79 | 0.736 | 1.45 | 0.175 | 2.0 |
| | Medium steel | 2.65 | 21.7 | 21.1 | 16.2 | 205 | 155 | 0.067 | 0.71 | 0.656 | 1.22 | 0.205 | 2.0 |
| | Copper (Table X) | 0.70 | 15.045 | 14.965 | 13.6 | 145 | 31.6 | 0.047 | 0.08 | 0.108 | 0.28 | 0.145 | 1.4 |
| | Copper (Table Y) | 1.00 | 15.045 | 14.965 | 13.0 | 133 | 44.1 | 0.047 | 0.11 | 0.145 | 0.39 | 0.133 | 1.4 |
| 15mm | Copper (Table Z) | 0.50 | 15.045 | 14.965 | 14.0 | 154 | 22.9 | 0.047 | 0.06 | 0.080 | 0.20 | 0.154 | 1.4 |
| 20mm 3/4" | Heavy steel | 3.25 | 27.2 | 26.6 | 20.4 | 326 | 243 | 0.085 | 1.75 | 1.29 | 1.90 | 0.326 | 2.4 |
| | Medium steel | 2.65 | 27.2 | 26.6 | 21.6 | 367 | 203 | 0.085 | 1.50 | 1.11 | 1.58 | 0.367 | 2.4 |
| | Copper (Table X) | 0.90 | 22.055 | 21.975 | 20.2 | 321 | 59.6 | 0.069 | 0.33 | 0.303 | 0.52 | 0.321 | 1.4 |
| | Copper (Table Y) | 1.20 | 22.055 | 21.975 | 19.6 | 302 | 78.3 | 0.069 | 0.43 | 0.387 | 0.69 | 0.302 | 1.4 |
| 22mm | Copper (Table Z) | 0.60 | 22.055 | 21.975 | 20.8 | 340 | 40.2 | 0.069 | 0.23 | 0.210 | 0.35 | 0.340 | 1.4 |
| 25mm 1" | Heavy steel | 4.05 | 34.2 | 33.4 | 25.7 | 518 | 380 | 0.106 | 4.29 | 2.54 | 2.97 | 0.518 | 2.7 |
| | Medium steel | 3.25 | 34.2 | 33.4 | 27.3 | 586 | 312 | 0.106 | 3.70 | 2.20 | 2.44 | 0.586 | 2.7 |
| | Copper (Table X) | 0.90 | 28.055 | 27.975 | 26.2 | 540 | 76.7 | 0.085 | 0.71 | 0.504 | 0.68 | 0.540 | 1.7 |
| | Copper (Table Y) | 1.20 | 28.055 | 27.975 | 25.6 | 516 | 101 | 0.085 | 0.91 | 0.650 | 0.89 | 0.516 | 1.7 |
| 28mm | Copper (Table Z) | 0.60 | 28.055 | 27.975 | 26.8 | 565 | 51.7 | 0.085 | 0.49 | 0.347 | 0.46 | 0.565 | 1.7 |
| 32mm 1 1/4" | Heavy steel | 4.05 | 42.9 | 42.1 | 34.3 | 927 | 490 | 0.134 | 9.16 | 4.31 | 3.84 | 0.926 | 2.7 |
| | Medium steel | 3.25 | 42.9 | 42.1 | 35.9 | 1016 | 461 | 0.134 | 7.74 | 3.64 | 3.14 | 1.016 | 2.7 |
| | Copper (Table X) | 1.20 | 35.07 | 34.99 | 32.6 | 837 | 128 | 0.110 | 1.83 | 1.043 | 1.12 | 0.837 | 1.7 |
| | Copper (Table Y) | 1.50 | 35.07 | 34.99 | 32.0 | 806 | 158 | 0.110 | 2.22 | 1.270 | 1.39 | 0.806 | 1.7 |
| 35mm | Copper (Table Z) | 0.70 | 35.07 | 34.99 | 33.6 | 889 | 75.5 | 0.110 | 1.11 | 0.635 | 0.67 | 0.889 | 1.7 |
| 40mm 1 1/2" | Heavy steel | 4.05 | 48.8 | 48.0 | 40.2 | 1272 | 566 | 0.152 | 13.98 | 5.79 | 4.43 | 1.271 | 3.0 |
| | Medium steel | 3.25 | 48.8 | 48.0 | 41.9 | 1376 | 461 | 0.152 | 11.78 | 4.87 | 3.61 | 1.376 | 3.0 |
| | Copper (Table X) | 1.20 | 42.07 | 41.99 | 39.6 | 1234 | 154 | 0.132 | 3.21 | 1.528 | 1.36 | 1.234 | 2.0 |
| | Copper (Table Y) | 1.50 | 42.07 | 41.99 | 39.0 | 1197 | 191 | 0.132 | 3.93 | 1.869 | 1.69 | 1.197 | 2.0 |
| 42mm | Copper (Table Z) | 0.80 | 42.07 | 41.99 | 40.4 | 1284 | 104 | 0.132 | 2.20 | 1.048 | 0.91 | 1.284 | 2.0 |
| 50mm 2" | Heavy steel | 4.50 | 60.8 | 59.8 | 51.3 | 2070 | 784 | 0.189 | 30.8 | 10.2 | 6.17 | 2.070 | 3.4 |
| | Medium steel | 3.65 | 60.8 | 59.8 | 53.0 | 2205 | 651 | 0.189 | 26.2 | 8.7 | 5.10 | 2.205 | 3.4 |
| | Copper (Table X) | 1.20 | 54.07 | 53.99 | 51.6 | 2095 | 199 | 0.170 | 7.0 | 2.573 | 1.76 | 2.095 | 2.0 |
| | Copper (Table Y) | 2.00 | 54.07 | 53.99 | 50.0 | 1965 | 327 | 0.170 | 11.1 | 4.101 | 2.88 | 1.965 | 2.0 |
| 54mm | Copper (Table Z) | 0.90 | 54.07 | 53.99 | 52.2 | 2145 | 150 | 0.170 | 5.3 | 1.963 | 1.33 | 2.145 | 2.0 |
| 65mm 2 1/2" | Heavy steel | 4.50 | 76.6 | 75.4 | 67.0 | 3530 | 1005 | 0.239 | 64.5 | 17.0 | 7.90 | 3.530 | 3.7 |
| | Medium steel | 3.65 | 76.6 | 75.4 | 68.7 | 3700 | 831 | 0.239 | 54.5 | 14.3 | 6.51 | 3.700 | 3.7 |
| | Copper (Table X) | 1.20 | 66.75 | 66.60 | 64.3 | 3245 | 247 | 0.209 | 13.2 | 3.97 | 2.18 | 3.245 | 2.0 |
| | Copper (Table Y) | 2.00 | 66.75 | 66.60 | 63.1 | 3125 | 406 | 0.209 | 21.3 | 6.38 | 3.58 | 3.125 | 2.0 |
| 67mm | Copper (Table Z) | 1.00 | 66.75 | 66.60 | 64.7 | 3285 | 206 | 0.209 | 11.1 | 3.34 | 1.82 | 3.285 | 2.0 |
| 80mm 3" | Heavy steel | 4.85 | 89.5 | 88.1 | 79.0 | 4905 | 1285 | 0.279 | 114 | 25.6 | 10.1 | 4.905 | 3.7 |
| | Medium steel | 4.05 | 89.5 | 88.1 | 80.7 | 5115 | 1080 | 0.279 | 97.0 | 21.8 | 8.47 | 5.115 | 3.7 |
| | Copper (Table X) | 1.50 | 76.3 | 76.15 | 73.2 | 4210 | 352 | 0.239 | 24.4 | 6.45 | 3.11 | 4.210 | 2.4 |
| | Copper (Table Y) | 2.00 | 76.3 | 76.15 | 72.2 | 4100 | 467 | 0.239 | 31.9 | 8.43 | 4.11 | 4.100 | 2.4 |
| 76mm | Copper (Table Z) | 1.20 | 76.3 | 76.15 | 73.8 | 4280 | 283 | 0.239 | 19.9 | 5.22 | 2.50 | 4.280 | 2.4 |
| 100mm 4" | Heavy steel | 5.40 | 114.9 | 113.3 | 103.3 | 8380 | 1840 | 0.358 | 272 | 47.7 | 14.4 | 8.380 | 4.1 |
| | Medium steel | 4.50 | 114.9 | 113.3 | 105.1 | 8680 | 1540 | 0.358 | 231 | 40.6 | 12.1 | 8.680 | 4.1 |
| | Copper (Table X) | 1.50 | 108.25 | 108.0 | 105.1 | 8680 | 504 | 0.340 | 71.4 | 13.21 | 4.45 | 8.680 | 2.7 |
| | Copper (Table Y) | 2.00 | 108.25 | 108.0 | 103.1 | 8355 | 832 | 0.340 | 115 | 21.41 | 7.33 | 8.355 | 2.7 |
| 108mm | Copper (Table Z) | 1.20 | 108.25 | 108.0 | 105.7 | 8780 | 405 | 0.340 | 71.2 | 10.66 | 3.57 | 8.780 | 2.7 |
| 125mm 5" | Heavy steel | 5.40 | 140.6 | 138.7 | 127.7 | 13050 | 2270 | 0.438 | 520 | 73.4 | 17.8 | 13.05 | 4.4 |
| | Medium steel | 4.85 | 140.6 | 138.7 | 129.8 | 13250 | 2065 | 0.438 | 470 | 67.4 | 16.2 | 13.25 | 4.4 |
| | Copper (Table X) | 1.50 | 133.5 | 133.25 | 130.4 | 13350 | 621 | 0.419 | 134 | 20.26 | 5.47 | 13.35 | 3.0 |
| | Copper (Table Y) | NA | NA | NA | NA | NA | NA | NA | NA | NA | NA | NA | NA |
| 133mm | Copper (Table Z) | 1.50 | 133.5 | 133.25 | 130.4 | 13350 | 621 | 0.419 | 134 | 20.26 | 5.47 | 13.35 | 3.0 |
| 150mm 6" | Heavy steel | 5.40 | 166.1 | 164.1 | 154.3 | 18700 | 2700 | 0.518 | 862 | 105 | 21.2 | 18.70 | 4.8 |
| | Medium steel | 4.85 | 166.1 | 164.1 | 155.3 | 18950 | 2455 | 0.518 | 787 | 95.4 | 19.2 | 18.95 | 4.8 |
| | Copper (Table X) | 2.00 | 159.5 | 159.25 | 155.4 | 18950 | 988 | 0.501 | 304 | 38.42 | 8.71 | 18.95 | 2.7 |
| | Copper (Table Y) | NA | NA | NA | NA | NA | NA | NA | NA | NA | NA | NA | NA |
| 159mm | Copper (Table Z) | 1.50 | 159.5 | 159.25 | 156.4 | 19200 | 743 | 0.501 | 230 | 29.09 | 6.55 | 19.20 | 2.7 |

Steel pipes are based on BS1387.

Copper pipes are based on BS2871.

N.MINIKIN AND SONS LIMITED CONDITIONS OF BUSINESS

1.00

The following conditions ("the Conditions") apply to and are deemed to be incorporated in all contracts for the sale of Goods by N. Minikin & Sons Limited ("the Company") to the buyer and the provision of advice or other services ("Services") by Salesmen or Engineers employed by the Company either during telephone negotiations or site or office visits and the Buyer acknowledges that these Conditions exclusively define the relationship and agreement between the Company and Buyer and that they supersede all other agreements and conditions between the parties. No variation in these Conditions, expressed or implied, shall be accepted by the Company unless expressly agreed in writing and signed by a director of the Company and signed on behalf of the Buyer

2.00

To the extent that these Conditions limit or exclude the liability of the Company to the Buyer or any person claiming through or under the buyer such limitation or exclusion of liability is imposed to avoid the need for the Company to increase the level of its insurance against the risks so limited or excluded, and thereby to minimise the cost to the Buyer of the Goods or Services supplied. If the Buyer nevertheless wishes the Company to be responsible for risks, or liability which is otherwise limited or excluded by these Conditions, then the Company will, at its option, quote an alternative price for the supply of the Goods or Services to reflect the additional cost of obtaining the appropriate additional insurance or other appropriate cover

3.00

All orders for the Goods made by the Buyer, orally or by telephone, shall be confirmed to the Company by the Buyer, in writing (including telex or fax) within 48 hours of being received by the Company whereupon a binding contract for the purchase by the Buyer of the Goods comprised in the order upon these Conditions shall be concluded. Any order made by the Buyer is subject to acceptance by the Company and a Contract will only be formed when the Company has accepted the Buyer's offer to buy

4.00

CANCELLATION AND RETURNS

4.01

No cancellation by the Buyer is permitted except where previously agreed in writing by a Director of the Company

4.02

The Buyer will in the event of cancellation by the Buyer not previously agreed as aforesaid indemnify the company fully against all expenses incurred up to the time of such cancellation together with by way of liquidated damages a sum of 50% of the contract price such sum being intended to represent a genuine pre-estimate by the Company and the Buyer of the loss (apart from the said expenses) suffered by the Company by reason of such cancellation and which shall be paid by the Buyer to the Company forthwith on cancellation

4.03

Goods supplied cannot be returned for credit without the previous approval in writing of the Company. A minimum handling charge of 30% will be made on the value of the Goods returned together with all carriage charges shall be paid by the Buyer. Specially manufactured items cannot be returned after delivery and orders for such items cannot be cancelled

5.00

DELIVERY

5.01

The Buyer shall accept delivery by the Company or its agents on the date, or within the time period stipulated by the Company. However, any time or period for delivery stipulated by the Company shall be deemed an estimate only and the Company shall not be liable in any way for the costs and consequences of any delay except where the parties agree otherwise in writing

5.02

The Company may make and the Buyer shall accept deliveries of the Goods comprised in any order by instalments

5.03

Delivery will be made by or on behalf of the Company to anywhere within the United Kingdom specified by the Buyer. Delivery to the Buyer's carrier or agent shall be deemed to be delivery to the buyer for the purpose of these Conditions of Business

6.00

TERMS OF PAYMENT

6.01

Unless otherwise expressly agreed in writing in accordance with Condition 1 payment for the Goods or Services will be made within 30 days after the end of the month in which the Goods or Services in question are delivered or rendered to the Buyer (except for any of the Goods in respect of which a claim has been made by the Buyer in accordance with Condition 12.00 hereof) No discount or allowance shall be made (unless otherwise agreed). Interest on any overdue account may be charged on a day to day basis, with monthly rests, at a rate of 4% above the base lending rate of National Westminster Bank Plc from time to time, whether before or after judgement

6.02

Value Added Tax at the rate from time to time ruling shall be added to the price and shall form part of the purchase price of the Goods or Services for the purpose of these Conditions

7.00

If the Buyer fails to make payment in accordance with Condition 6.00 the Company reserves the right to discontinue, defer or suspend the supply to the buyer of any other of the Goods or Services contracted to be supplied and the Company shall be entitled to claim against the Buyer for any loss or damage whatsoever sustained by it in consequence thereof

8.00

If the Buyer shall be unable or unwilling for any reason to take delivery of the Goods or Services on the specified date or within the specified period, delivery shall for the purposes of calculating time for payment in accordance with Condition 6.00 be deemed to have taken place 14 days after the said date or period. The Company reserves the right to charge the Buyer for the cost of storage, labour, insurance and transport if the Buyer shall be unable or unwilling to take delivery of the Goods or Services as aforesaid

9.00

PRICE

9.01

The Goods or Services will be sold to the Buyer at the prices agreed at time of order placed by the Buyer. The Company reserves the right to increase prices specified in the price list issued by the Company without notice to take account of any change in cost of wages, materials, insurance, transport, duty, tax, surcharge or levy of any kind

9.02

Any price quoted by the Company or contained in any order or contract shall be valid only for 28 days from the date of such quotation, order or contract

9.03

Carriage by the Company's normal transport in Great Britain is paid on orders over £750 value. Delivery of export orders will be F.O.B. the relevant United Kingdom port. Special packing or special delivery requirements will be charged extra

9.04

The Company shall not be liable for any loss whatsoever or howsoever arising caused by its non-delivery or by the failure to make Goods available ready for collection on the due date

10.00

PROPERTY OF THE GOODS

10.01

Notwithstanding risk in the Goods passes to the Buyer as soon as the Goods become ascertained Goods and subject as provided below, the Goods shall remain the sole and absolute property of the Company and title to and legal and equitable ownership of the Goods shall not pass to the Buyer until payment is received by the Company for all monies due from the buyer to the Company in respect of all Goods supplied by the Company to the Buyer and the buyer acknowledges that until such payment is made in full it is in possession of the Goods solely as a fiduciary for the Company

10.02

If Goods the property of the Company are admixed with Goods being the property of the Buyer or are processed or incorporated therein the product thereof will become or deemed to be the sole and exclusive property of the Company

10.03

If Goods the property of the Company are admixed with Goods the property of any person other than the Buyer or are processed or incorporated therein the product thereof shall become or deemed to be owned in common with that other person in proportion to the respective invoice values of the Goods comprised in such product

10.04

The Buyer is licensed by the Company to use or to agree to sell the Goods provided that the entire proceeds of sale of such Goods (or if such Goods have been converted into some other product or mixed with other Goods being the property of some person other than the Buyer a fair proportion of the proceeds of sale) are held in trust for the Company are not mixed with other monies or paid into an overdrawn bank account and shall at all times be identifiable as the Company's money

10.05

Until title to the Goods passes to the buyer the Goods shall be kept separate and distinct from all other property of the Buyer and of third parties and in good condition and stored in such a way as to be clearly identifiable as belonging to the Company and the buyer will not cause or permit or suffer any labels, badges, serial numbers, packaging or other means of identification of the Goods to be removed or obscured

10.06

Without prejudice to any other right or remedies available to it the Company may for the purpose of recovering its Goods and at any time before payment to it of all monies due from the Buyer enter upon any premises where such goods are stored or where they are reasonably thought to be stored and may re possess the same

10.07

If the Buyer being an individual commits any act of bankruptcy or enters into or takes steps to enter into an individual voluntary arrangement under the Insolvency Act 1986 or being a company enters into liquidation (whether compulsory or voluntary) or has a receiver appointed over the whole or any part of its assets or is the subject of an administration order or any person becomes entitled to exercise the powers conferred on an administrative receiver and any payment due from the Buyer to the Company is overdue in whole or in part or the Buyer is unable to meet its obligations as and when they fall due then the Company may (without prejudice to any of its other rights) recover or re-sell the Goods or any of them and may enter upon the Buyer's premises by its servants or agents, for that purpose

11.00

11.01 Where the Goods are ordered by reference to any sample the Company shall use its best endeavours to ensure that the bulk corresponds with the sample

11.02

The Company warrants that the Goods supplied or Services given to the Buyer will be suitable for the primary purpose for which the Goods and Services given is/are made and normally used. Subject thereto no warranty is given or to be implied as to the suitability of the Goods or Services given for any particular purpose or for use under any specific conditions unless such purpose or conditions have been previously agreed in writing by the Company

11.03

In connection with the supply of the Goods the Company warrants to the Buyer in the terms implied by Section 12 of the Sale of Goods Act 1979 as to title, quiet possession and freedom from encumbrances of the Goods but except as aforesaid and without prejudice to the generality of paragraphs 12.01 and 12.02 of these Conditions, the Company gives no warranty whether expressed or implied, by law or otherwise as regards the Goods supplied by it provided that in the event of the Company's negligence nothing herein shall limit or exclude the Company's liability for personal injury or death

11.04

Subject to the operation of any other specific provisions of these Conditions the Buyer's remedies against the Company in respect of any liability of the Company, whether in contract or in tort, shall not exceed the sum of £50,000 or the invoice value of the Goods directly giving rise to the claim or loss (whichever is less) for the Buyer's direct financial loss and any indirect or consequential loss (including loss of profit) suffered by the Buyer or for any claim made against the Buyer by a third party

Subject to the provisions of paragraph 11.00:-

12.01

All claims for loss caused by damage in transit, in storage or on delivery by the Company must be notified in writing by the Buyer to the Company within three days after receipt of the Goods and must within seven days thereafter be supported by a detailed written claim by the Buyer to the Company

12.02

All claims for non delivery, shortages, variances in design, or incorrect specification must be notified to the Company by the Buyer verbally or by telephone, telex, or fax no later than three days after the date of delivery in the case of claims for variances in design or incorrect specification and no later than 48 hours after the date for delivery in the case of claims for non delivery and shortages and in all such cases confirmed in writing no later than seven days after the date of delivery and it is expressly provided that no claims for shortages, variances in design or incorrect specification shall be accepted in whole or in part if the Goods in question have been installed or cut or worked-upon by the Buyer or its employees or agents

12.03

The risk of accidental loss whilst the Goods are being returned will be borne by the Buyer

12.04

Time shall be of the essence in respect of any notification to be given by the Buyer to the Company in accordance with this paragraph 12

13.00

Any failure on the part of the Company to exercise, or any delay by the Company in exercising, any right or remedy available to it, whether contained in these Conditions or otherwise, shall not operate as a waiver of such right nor shall any single or partial exercise by the Company of such right or remedy preclude the exercise, successively or concurrently of any right or remedy. Subject to the provisions of Condition 1, no waiver by the Company, whether as a part of the course of dealings between the Company and the Buyer, or otherwise of any time limit specified in these Conditions shall be effective

14.00

The Company shall not be liable or deemed to be in default for any delay or failure to perform its obligations under these Conditions if such delay or failure results directly or indirectly from any cause beyond the reasonable control of the Company, including, but not limited to, acts or restraints of government or governmental agencies, force majeure, act of God, war, riot, civil or criminal disturbance, insurrection, accidents, fire, explosion, earthquake, flood, the elements, strikes, labour disputes, shortages of suitable material, labour or transport

15.00

The Company shall be entitled forthwith to terminate any contract incorporating these Conditions and payment thereunder shall immediately become due if the Buyer shall make any default in or commit a breach of these Conditions or of any of its obligations to the Company or if any distress or execution shall be threatened or levied on the Buyer's property or assets, or if the Buyer shall make or offer to make any arrangement or composition with creditors or seek to obtain pursuant to statute or otherwise any moratorium with creditors or shall pass any resolution or shall suffer a petition to be presented for the winding-up of the Buyer (other than for the purpose of a solvent amalgamation or reconstruction notified to the Company) or if a receiver or manager of the Buyer's undertaking, property or assets or any part thereof shall be appointed without prejudice or any claim or right the Company might otherwise make or exercise

16.01

All contracts incorporating these Conditions shall be interpreted in accordance with the laws of England and shall be enforceable in the English Courts

16.02

Any contract incorporating these Conditions may not be assigned by the Buyer without the prior written consent of the Company

16.03

The obligations of the Company may be performed in whole or in part by its authorised distributors sub-contractors or agents at the discretion of the Company

16.04

In making these Conditions the Company does so for itself and for and on behalf of every employee servant sub-contractor or agent of the Company and the Buyer hereby confirms that any exemption from liability granted to the Company by these Conditions shall also extend to any such employee servant sub-contractor or agent of the Company

16.05

Any notice sent under a contract incorporating these Conditions shall be sent to the registered office of the Company or the Buyer (as the case may be) and shall be deemed duly given by letter 48 hours after being posted by pre-paid registered post or if delivered by hand at the time of delivery or if given by telex or fax when the sender shall receive the answerback of the recipient sent

ALSO AVAILABLE TO THE ENGINEER

- * **Technical Advice**
- * **CIBSE Recognised CPD Courses**
- * **Slide Rule: Expansion Joint Calculator**
- * **Standard Specifications**
- * **Technical Reports**
- * **Design Book: "The Application of Expansion Joints to Pipework Systems"**
- * **Anti Vibration Book**
- * **Air & Dirt Separators, Deaerators and Automatic Air Vents**
- * **Pipe Guides and Skids**
- * **Installation Instructions**
- * **Quality Assurance to BS EN ISO 9002**

Minikin is a Patron of the
Chartered Institution of
Building Services Engineers

N. Minikin & Sons Ltd

Technical Advisors & Suppliers to the Building Services Industry

Tel: 01423 889845 Fax: 01423 880724

Email: minikin@dial.pipex.com

Web Site: www.minikin.dial.pipex.com